



- Security and Emergency systems
- EN 54-16 · Conference systems & Intercom systems · Microphones
- Preamplifier equipment · Control equipment · Power amplifiers
- Integrated amplifiers · Music sources · Ceiling speakers · Sound projectors · EN 54-24 speakers
- Spherical diffusers · Speaker systems · Column speakers
- Weatherproof speakers

- Variable curvature line array
- Constant curvature line array
- Column line array · Point source
- Subwoofer · Monitor · Digital loudspeaker management
- Power amplifier · Accessories

- Line array systems · Speaker systems
- Subwoofer · Monitor · Integrated sound systems · Digital loudspeaker management · Power amplifier
- Accessories



since 1963  
Made in Italy

## 6 • Security and Emergency Systems

EN 54 - 16

- 6 Wall-mounted voice evacuation system
- 16 Controller EN 54-16
- 17 Router EN 54-16
- 18 Class D Modular Amplifiers / Main frame EN54-16
- 20 Emergency Paging Units EN54-16



## 24 • In-ceiling speakers • Sound projectors • Column speakers

EN 54 - 24

- 24 Wall speakers
- 25 Flush-mounting wall/ceiling speakers
- 26 Musical horn speakers
- 28 Sound Projector
- 30 Horn speaker
- 32 Column speakers
- 36 Constant Curvature Line Array-Point Source



## 41 • Conference Systems

- 41 Control unit
- 42 Expansion Kit



## 44 • Microphones • Microphones bases • Wireless microphones

- 44 Hand-held microphones
- 45 Gooseneck microphones
- 46 Condenser microphones
- 48 Microphone bases
- 49 Desktop bases
- 50 Pre-amplified broadcasting paging units
- 53 Wireless microphones
- 54 Wireless microphones UHF



57 • **Control Unit**  
 • **Power Unit**  
 • **Power Amplifier**  
 • **Music sources**  
 • **Rack and cabinets**

57 Preamplifier mixer  
 60 Zone preamplifier  
 61 Digital matrix mixer  
 66 Power Unit  
 68 Integrated amplifiers  
 72 Music distribution system  
 76 Music sources  
 78 Rack and cabinets



80 • **Ceiling speakers**  
 • **Sound Projector**  
 • **Spherical speakers**  
 • **Musical horn**

80 Wall or ceiling ABS speakers  
 82 Speakers for underwater and clean room applications  
 83 ABS surface mounting wall speakers and accessories  
 87 DHN and ABS Sound projectors  
 88 Spherical speaker  
 89 Musical horn speakers



93 • **Speaker systems**  
 • **Column speakers**

93 Speaker systems  
 94 ABS Speaker systems  
 100 Permanent installation speakers  
 103 Column speakers



107 • **Outdoor speakers**

107 All weather speakers  
 108 External sound speakers



110 Methods of installation  
 113 Index model -page reference

# HISTORY, EXPERIENCE AND INNOVATION IN TRADITION. MADE IN ITALY.

Since 1963, FBT designs and builds sound in Recanati, a small city located in the centre of Italy, a city of Poetry, of Art, of Music, from immemorial time the soundtrack for entire generations.

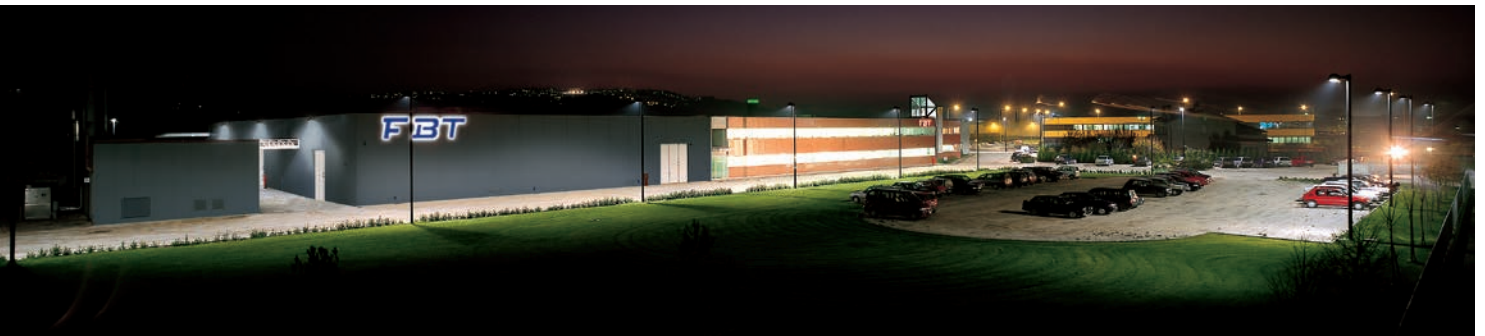

IN FBT EVERY DEPARTMENT  
IS A COMPANY  
IN THE COMPANY  
WHOSE AIM IS TO MAKE  
QUALITY WITHIN  
THE ENERGY OF SOUND.

A technological know-how that extends from research to planning, from electronics to design, from wood to metal, from plastics to painting. A highly innovative product and a manufacturing process determined by a strict final electronic testing.



# SECURITY AND EMERGENCY SYSTEMS

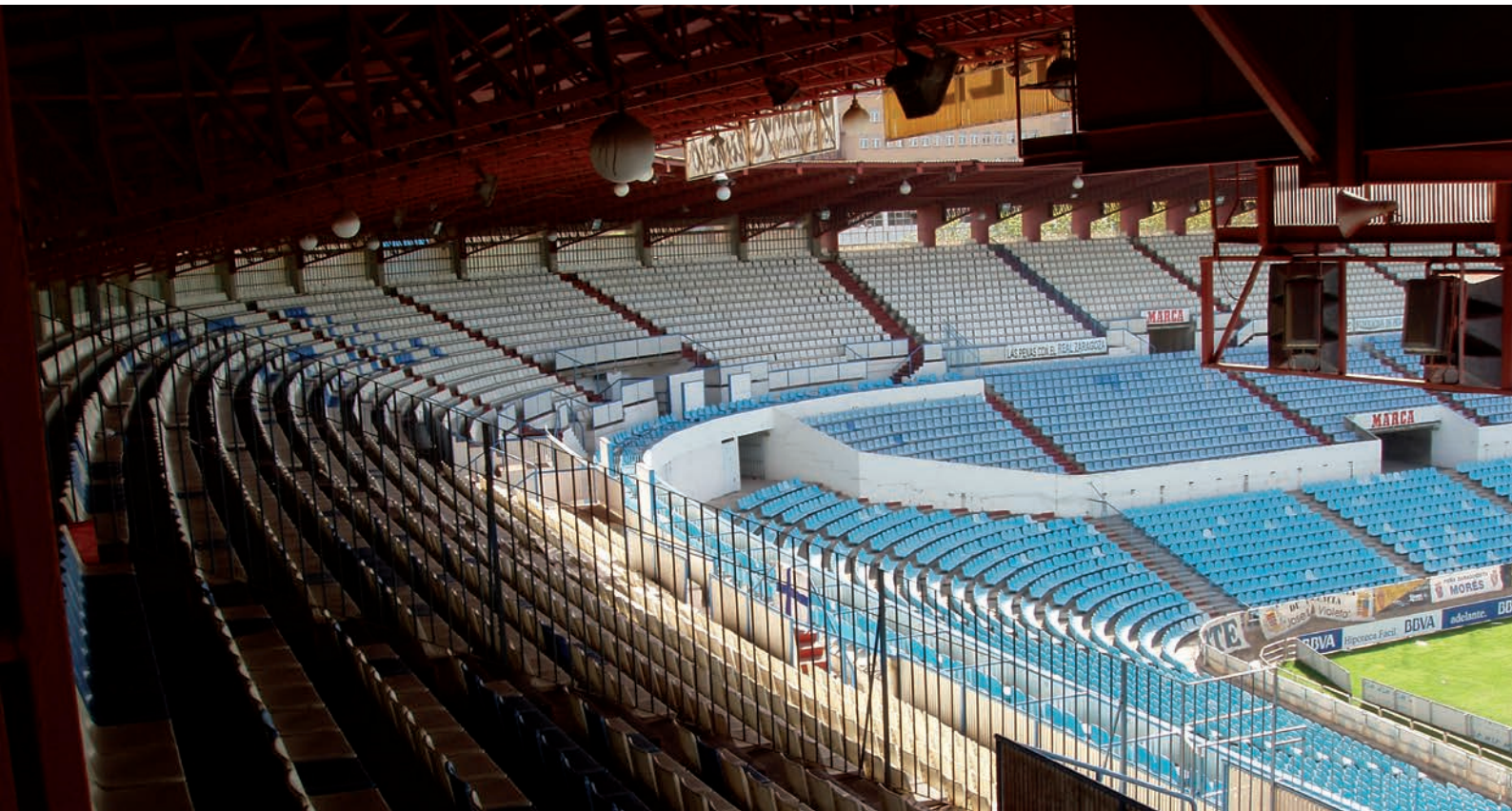

# 6 | Security and emergency systems EN 54

EN 54 - 16  
0068-CPR-013/2019



## VAIE 7M04

## VAIE 7M06

### ACPAW-RCK

**Code 42949**  
Support kit for rack mounting



### ACPAW-2IN

**Code 42947**  
2-input expansion



### ACPAW-6IN

**Code 42948**  
6-input expansion



**Code 42589**

**Code 42610**

### WALL-MOUNTED VOICE EVACUATION SYSTEM

These systems are able to manage, depending on the model, up to 6 alarm zones via local controls, remote microphone station and controlled inputs.

Two available models:

- **VAIE 7M04** - 1000W/4 zones
- **VAIE 7M06** - 1000W/6 zones
- Audio rated power: 1000 W freely distributed between the zones up to a maximum of 250 W (for each zone).
- 4.3" touch screen back-lighted display for Alert & Evacuation zone selection, levels adjustment, settings and failure visualization.
- Sending of EVACUATION and ALERT pre-recorded messages.
- Sending of BROADCAST pre-recorded messages.
- 1 off music input for sound sources.
- 1 off auxiliary input configurable as a music source, a call with precedence activation or a call with automatic activation (VOX).
- 3 off configurable relay outputs.
- Event log (list of failures and/or alarms that have occurred in the system).
- Double LINK line for connecting other VAIE 7M00 (up to a total of 6 units).
- Multilanguages management.
- 3-band equalisation for each zone output.

- 3-band equalisation for each music input.
- Optional internal expansion card ACPAW-2IN for two additional music inputs (EXT 1 and EXT 2).
- Optional internal expansion card ACPAW-6IN with DSP for six additional music inputs.
- Built-in SD/USB input for background music MP3 player.
- Independent selection on each zone of the various audio sources (MUSIC IN, AUX IN, MP3 player and EXT).
- Up to 8 pre-recorded messages can be retrieved from outside through input contacts (of which 2 fixed emergency messages - plus 6 that can be classed as emergency / evacuation / broadcast messages).
- Possibility of setting up to 16 timers for the programmed playing out of the broadcast messages with the possible activation of signalling relays.
- Up to 16 MBT 1106 and/or MBT 1112 broadcasting microphone stations can be connected.
- Up to 4 of the above mentioned stations can be set for local calls only (zones of the card-cage to which they are connected).
- Up to 4 FMD 2001 and FMD 1012 remote emergency units can be connected (or, as an alternative, up to 2 touch screen units TSC6000-EN).
- Mounting on 19" rack (optional, with ACPAW-RCK accessory kit).



	<b>VAIE 7M04</b>		<b>VAIE 7M06</b>	
<b>Code</b>	<b>42589</b>		<b>42610</b>	
Rated audio output @230VAC *typical distortion at 25 W 0,025%	W	1000 W / D=2,5%*		1000 W / D=2,5%*
Rated audio output @24VDC *typical distortion at 25 W 0,025%	W	800 W / D=10%*		800 W / D=10%*
Display		4.3", backlit with touch screen, 480x272 pixels		4.3", backlit with touch screen, 480x272 pixels
N° of VAIE 7500 x system		Max 6 (ID 0÷5)		Max 6 (ID 0÷5)
N° of zones/amplifiers		4		6
<b>INPUTS</b>				
<b>Emergency microphone</b>				
		Balanced XLR-F on the front door		Balanced XLR-F on the front door
Sensitivity / Impedance		Signal level: 20 mV / 10 k		Signal level 20 mV / 10 k
Frequency response   S/N ratio	Hz/dB	60÷20.000   72		60÷20.000   72
<b>Paging units (DESK)</b>				
		1 off Rj45 for paging units (PA)		1 off Rj45 for paging units (PA)
Sensitivity / Impedance		Signal level: max. 1400 mV / 85 k		Signal level: max. 1400 mV / 85 k
Frequency response   S/N ratio	Hz/dB	60 ÷20.000   83		60 ÷20.000   83
<b>Emergency units (EMG. DESK)</b>				
		1 off Rj45 for emergency microphone stations		1 off Rj45 for emergency microphone stations
Sensitivity / Impedance		Signal level: max. 1400 mV / 85 k		Signal level: max. 1400 mV / 85 k
Frequency response   S/N ratio	Hz/dB	60÷20.000   83		60÷20.000   83
<b>AUX (LINE-VOX)</b>				
		Balanced with terminals (HOT-COM-GND) Programmable in ON / OFF / VOX with A.P.T. modes Precedence input with contact closing activation		Balanced with terminals (HOT-COM-GND) Programmable in ON / OFF / VOX with A.P.T. modes Precedence input with contact closing activation
Sensitivity / Impedance		134 mV / 31 k		134 mV / 31 k
Frequency response   S/N ratio	Hz/dB	90÷20.000   81 dB / 85 dBA		90÷20.000
<b>Music</b>				
		Balanced with terminals (HOT-COM-GND)		Balanced with terminals (HOT-COM-GND)
Sensitivity / Impedance		134 mV / 31 k		134 mV / 31 k
Frequency response   S/N ratio	Hz/dB	90÷20.000   81 dB / 85 dBA		90÷20.000   81 dB / 85 dBA
<b>Equalisation</b>				
Independent equalisation for each output zone Independent equalisation for each music input		3-band equaliser Bass tones (100 Hz): ± 10 dB Mid-range (1 kHz): ± 10 dB Treble tones (10 kHz): ± 10 dB		3-band equaliser Bass tones (100 Hz): ± 10 dB Mid-range (1 kHz): ± 10 dB Treble tones (10 kHz): ± 10 dB
<b>OUTPUTS</b>				
<b>Constant voltage outputs W/double lines (A/B)</b>				
One zone output can be confi gured as a standby for the others.		4 zones for 100V lines Minimum 40 Ω		6 zones for 100V lines Minimum 40 Ω
<b>Remote Link (A/B)</b>				
		n°2+2 Rj45 for connection with another VAIE 7M00 and/or VAIE 7500		n°2+2 Rj45 for connection with another VAIE 7M00 and/or VAIE 7500
Output level / Impedance		1 V / 400 Ω		1 V / 400 Ω
Sensitivity / Input impedance		3600 mV / 3 kΩ		3600 MV / 3 KΩ
<b>Emergency controls</b>				
		Programmable for normally active or normally inactive state		Programmable for normally active or normally inactive state
Controlled inputs CONT. IN		7 off inputs with diagnostic		7 off inputs with diagnostic
Outputs R1, R2, R3		3 off relays for signalling, state of emergency and faults, N.O-N.C-Exchange state		3 off relays for signalling, state of emergency and faults, N.O-N.C-Exchange state
<b>General information</b>				
Mains power supply @230VAC Consumption @230VAC		100 ~ 264 Vac - 47/63Hz - 1280 W full load (4amp active) - 100 W no load		100 ~ 264 Vac - 47/63Hz - 1280 W full load (4amp active / 2amp stand-by) - 100 W no load
Secondary power supply @24 VDC (26,3 VDC) Secondary power supply Consumption @24 VDC		40 A full load  2 A no load / quiescent 0,3 A no load / energy saving		40 A full load  2 A no load / quiescent 0,3 A no load / energy saving
Batteries (not included)		Only use 40 Ah batteries		Only use 40 Ah batteries
Charger / Power supply unit		16 A (I max. a) / 20 A (I max. b) 21 V (fi nal voltage – detached battery) 27,2 V (complete load voltage)		16 A (I max. a) / 20 A (I max. b) 21 V (fi nal voltage – detached battery) 27,2 V (complete load voltage)
Environmental operating conditions		Temperature: +5°C ÷ +40°C Relative humidity: 25% to 75% (non-condensing)		Temperature: +5°C ÷ +40°C Relative humidity: 25% to 75% (non-condensing)
Type of mounting		Wall / To 19" rack with ACPAW-RCK optional accessory		Wall / To 19" rack with ACPAW-RCK optional accessory
Dimensions (WxHxD)	mm	430x 620x240		430x 620x240
Weight	Kg	22		22

# 8 | Security and emergency systems EN 54

EN 54 - 16  
0068-CPR-013/2019



## VAIE 7502

Code 41812

## VAIE 7504

Code 41813

## VAIE 7506

Code 41814

### WALL-MOUNTED VOICE EVACUATION SYSTEM

These systems are able to manage, depending on the model, up to 6 alarm zones via local controls, remote microphone station and controlled inputs. Three available models:

**VAIE 7502** - 500W/2 zones

**VAIE 7504** - 500W/4 zones

**VAIE 7506** - 500W/6 zones

- Rated audio output: 500 W overall, distributable freely among the zones with a maximum limit of 250 W per single zone.
- Backlit 4.3" display with touch screen for selecting the alert and evacuation zones and enabling navigation for adjusting volume levels, configuring the equipment and viewing failures.
- Handheld fireman's microphone (included).
- Sending out of pre-recorded EVACUATION and ALERT messages.
- Listening to pre-recorded messages through local loudspeaker.
- 7 off controlled input contacts, configurable for playing the evacuation and/or alert and/or broadcast messages to the programmed zones or for resetting the messages.
- 1 off music input for sound sources.
- 1 off auxiliary input configurable as a music source, a call with precedence activation or a call with automatic activation (VOX).
- 3 off configurable relay outputs.

- Double A+B output for each zone.
- Events log (report of all faults and/or alarms occurred in the system).
- Double LINK line to connect further VAIE 7500 (up to 6 units).
- Multilingual managing software (up to 8 languages, ASCII characters).
- Protected local button for placing the system in an emergency state, equipped with its own LED.
- Local button for resetting the fault acoustic signal and stopping playing out of alarm messages.
- Possibility to play MP3 files through SD card and/or external USB device.
- Independent selection on each zone of the various sound sources (MUSIC IN, AUX IN or SD/USB IN).
- Possibility to recall through the input contacts up to 8 pre-recorded messages (2 emergency messages - 1 alert, 1 evacuation - and the other 6 classifiable as emergency/evacuation/broadcast).
- Possibility to set as local the broadcasting microphone station.
- Up to 16 broadcasting microphone stations can be connected (MBT 1106 and/or MBT 1112).
- Up to 4 FMD 2001 and/or FMD 2012 remote emergency units can be connected (or, as an alternative, 2 touchscreen units TSC6000-EN).
- EN54-4 certified internal battery charger unit for 24Vdc secondary power supply (batteries not supplied).
- Industry-standard 19" rack-mounting format (optional).





	VAIE 7502	VAIE 7504	VAIE 7506
<b>Code</b>	<b>41812</b>	<b>41813</b>	<b>41814</b>
Rated audio output @230VAC *typical distortion at 25 W 0,025%	W 500 W / D=2,5%*	500 W / D=2,5%*	500 W / D=2,5%*
Rated audio output @24VDC *typical distortion at 25 W 0,025%	W 400 W / D=10%*	400 W / D=10%*	400 W / D=10%*
Display	4.3", backlit with touch screen, 480x272 pixels	4.3", backlit with touch screen, 480x272 pixels	4.3", backlit with touch screen, 480x272 pixels
N° of VAIE 7500 x system	Max 6 (ID 0÷5)	Max 6 (ID 0÷5)	Max 6 (ID 0÷5)
N° of zones/amplifiers	2	4	6
<b>INPUTS</b>			
<b>Emergency microphone</b>	Balanced XLR-F on the front door	Balanced XLR-F on the front door	Balanced XLR-F on the front door
Sensitivity / Impedance	Signal level: 20 mV / 10 k	Signal level 20 mV / 10 k	Signal level 20 mV / 10 k
Frequency response	Hz 60÷20.000	60÷20.000	60÷20.000
S/N ratio	dB 72	72	72
<b>Paging units (DESK)</b>	1 off Rj45 for paging units (PA)	1 off Rj45 for paging units (PA)	1 off Rj45 for paging units (PA)
Sensitivity / Impedance	Signal level: max. 1400 mV / 85 k	Signal level: max. 1400 mV / 85 k	Signal level: max. 1400 mV / 85 k
Frequency response	Hz 60 ÷20.000	60 ÷20.000	60 ÷20.000
S/N ratio	dB 83	83	83
<b>Emergency units (EMG. DESK)</b>	1 off Rj45 for emergency microphone stations	1 off Rj45 for emergency microphone stations	1 off Rj45 for emergency microphone stations
Sensitivity / Impedance	Signal level: max. 1400 mV / 85 k	Signal level: max. 1400 mV / 85 k	Signal level: max. 1400 mV / 85 k
Frequency response	Hz 60÷20.000	60÷20.000	60÷20.000
S/N ratio	dB 83	83	83
<b>AUX (LINE-VOX)</b>	Balanced with terminals (HOT-COM-GND) Programmable in ON / OFF / VOX with A.P.T. modes Precedence input with contact closing activation	Balanced with terminals (HOT-COM-GND) Programmable in ON / OFF / VOX with A.P.T. modes Precedence input with contact closing activation	Balanced with terminals (HOT-COM-GND) Programmable in ON / OFF / VOX with A.P.T. modes Precedence input with contact closing activation
Sensitivity / Impedance	134 mV / 31 k	134 mV / 31 k	134 mV / 31 k
Frequency response	Hz 90÷20.000	90÷20.000	90÷20.000
S/N ratio	dB 81 dB / 85 dBA	81 dB / 85 dBA	81 dB / 85 dBA
<b>Music</b>	Balanced with terminals (HOT-COM-GND)	Balanced with terminals (HOT-COM-GND)	Balanced with terminals (HOT-COM-GND)
Sensitivity / Impedance	134 mV / 31 k	134 mV / 31 k	134 mV / 31 k
Frequency response	Hz 90÷20.000	90÷20.000	90÷20.000
S/N ratio	dB 81 dB / 85 dBA	81 dB / 85 dBA	81 dB / 85 dBA
<b>OUTPUTS</b>			
<b>Constant voltage outputs With double lines (A/B)</b> One zone output can be configured as a standby for the others.	2 zones for 100V lines Minimum 40	4 zones for 100V lines Minimum 40	6 zones for 100V lines Minimum 40
<b>Link</b>	4 off Rj45 for connection with another VAIE 7500-VES unit	4 off Rj45 for connection with another VAIE 7500-VES unit	4 off Rj45 for connection with another VAIE 7500-VES unit
Output level / Impedance	1 V / 400	1 V / 400 Ω	1 V / 400 Ω
Sensitivity / Input impedance	3600 mV / 3 kΩ	3600 MV / 3 KΩ	3600 MV / 3 KΩ
<b>Emergency controls</b>	Programmable for normally active or normally inactive state	Programmable for normally active or normally inactive state	Programmable for normally active or normally inactive state
Controlled inputs CONT. IN	7 off inputs with diagnostic	7 off inputs with diagnostic	7 off inputs with diagnostic
Outputs R1, R2, R3	3 relays for signalling, state of emergency and faults, N.O-N.C-Exchange state	3 relays for signalling, state of emergency and faults, N.O-N.C-Exchange state	3 relays for signalling, state of emergency and faults, N.O-N.C-Exchange state
<b>General information</b>			
Mains power supply @230VAC Consumption @230VAC	230Vca 50/60Hz +10/-15% 646 W full load (2amps active) 36 W a vuoto	230Vca 50/60Hz +10/-15% 653 W full load (2amps active / 2amp standby)	230Vca 50/60Hz +10/-15% 660 W full load (2amps active / 4amp standby) Efficiency: 75,6%
Secondary power supply @24 VDC (26,3 VDC)	20 A full load	20 A full load	20 A full load
Secondary power supply Consumption @24 VDC	0,7 A no load/ quiescent 0,2 A no load / energy saving	0,95 A no load / quiescent 0,2 A no load / energy saving	0,2 A no load / quiescent 0,2 A no load / energy saving
Batteries	Suggested model: W-MS12/28 (26÷28 Ah). It is possible to use other batteries (18 Ah - 33 Ah - 40 Ah)		
Environmental operating conditions	Temperature: +5°C ÷ +40°C Relative humidity: 25% to 75% (non-condensing)		
Type of mounting	Wall mounting	Wall mounting	Wall mounting
Dimensions (WxHxD)	mm 430x 620x240	430x 620x240	430x 620x240
Weight	Kg 19,3	19,3	19,3

# 10 | Security and emergency systems EN 54

The new **VAIE 6500 compact systems** - equipped with a EN54-16:2008 / EN54-4 certified control unit - have been designed for ease of installation and for operating in a vast range of applications.

EN 54 - 16  
0068-CPR-044/2016



## VAIE 6502

Code 40644

## VAIE 6504

Code 40948

## VAIE 6506

Code 40949

### WALL-MOUNTED VOICE EVACUATION SYSTEM

These systems are able to manage, depending on the model, up to 6 alarm zones via local controls, remote microphone station and controlled inputs. Three available models:

- **VAIE 6502** - 500W/2 zones - double line
- **VAIE 6504** - 500W/4 zones - double line
- **VAIE 6506** - 500W/6 zones - double line

- Audio rated power: 500 W freely distributed between the zones up to a maximum of 250W within a single zone
- 4.3" touch screen back-lighted display for alert & evacuation zone selection, levels adjustment, settings and failure visualization
- Fireman's monitored microphone on the front panel
- Sending of EVACUATION and ALERT pre-recorded messages
- 7 monitored inputs, each of which is configurable for the playback or either evacuation or alert messages, programmable for each zone, or for the reset of the messages

- 1 auxiliary input for external sound sources
- 1 VOX input
- 3 configurable relay outputs
- Double output A+B per zone
- Secure front-panel button for operating the emergency system complete with LED indicator
- Front-panel reset button
- Possibility to source either BGM or paging announcements from an auxiliary input or microphone
- Possibility to connect up to 16 paging units MBT 1106, MBT 1112
- Possibility to connect up to 4 remote emergency microphone units FMD 2001, FMD 2012 or, as an alternative, up to 2 touch screen remote emergency units TSC 6000-EN
- Possibility to connect further VAIE 6500 (up to 6 units)
- Industry-standard 19" rack-mounting format



	VAIE 6502	VAIE 6504	VAIE 6506
<b>Code</b>	<b>40644</b>	<b>40948</b>	<b>40949</b>
Rated audio output @230VAC *typical distortion at 25 W 0,025%	W 500 W / D=2,5%*	500 W / D=2,5%*	500 W / D=2,5%*
Rated audio output @24VDC *typical distortion at 25 W 0,025%	W 400 W / D=10%*	400 W / D=10%*	400 W / D=10%*
Display	4.3", backlit with touch screen, 480x272 pixels	4.3", backlit with touch screen, 480x272 pixels	4.3", backlit with touch screen, 480x272 pixels
N° of VAIE 6500 x system	Max 6 (ID 0÷5)	MAX 6 (ID 0÷5)	MAX 6 (ID 0÷5)
N° of zones/amplifiers	2	4	6
<b>INPUTS</b>			
<b>Emergency microphone</b>	Balanced XLR-F on the front door	Balanced XLR-F on the front door	Balanced XLR-F on the front door
Sensitivity / Impedance	Signal level: 20 mV / 10 kΩ	Signal level 20 mV / 10 kΩ	Signal level 20 mV / 10 kΩ
Frequency response	Hz 60÷20.000	60÷20.000	60÷20.000
S/N ratio	dB 83	83	83
<b>Paging units (DESK)</b>	1 off Rj45 for paging units (PA)	1 off Rj45 for paging units (PA)	1 off Rj45 for paging units (PA)
Sensitivity / Impedance	Signal level: max. 1400 mV / 85 kΩ	Signal level: max. 1400 mV / 85 kΩ	Signal level: max. 1400 mV / 85 kΩ
Frequency response	Hz 60 ÷20.000	60 ÷20.000	60 ÷20.000
S/N ratio	dB 72	72	72
<b>Emergency units (EMG. DESK)</b>	1 off Rj45 for emergency microphone stations	1 off Rj45 for emergency microphone stations	1 off Rj45 for emergency microphone stations
Sensitivity / Impedance	Signal level: max. 1400 mV / 85 kΩ	Signal level: max. 1400 mV / 85 kΩ	Signal level: max. 1400 mV / 85 kΩ
Frequency response	Hz 60÷20.000	60÷20.000	60÷20.000
S/N ratio	dB 83	83	83
<b>AUX (LINE-VOX)</b>	Balanced with terminals (HOT-COM-GND) Programmable in ON / OFF / VOX with A.P.T. modes Precedence input with contact closing activation	Balanced with terminals (HOT-COM-GND) Programmable in ON / OFF / VOX with A.P.T. modes Precedence input with contact closing activation	Balanced with terminals (HOT-COM-GND) Programmable in ON / OFF / VOX with A.P.T. modes Precedence input with contact closing activation
Sensitivity / Impedance	134 mV / 31 kΩ	134 mV / 31 kΩ	134 mV / 31 kΩ
Frequency response	Hz 90÷20.000	90÷20.000	90÷20.000
S/N ratio	dB 81 dB / 85 dBA	81 dB / 85 dBA	81 dB / 85 dBA
<b>Music</b>	Balanced with terminals (HOT-COM-GND)	Balanced with terminals (HOT-COM-GND)	Balanced with terminals (HOT-COM-GND)
Sensitivity / Impedance	134 mV / 31 kΩ	134 mV / 31 kΩ	134 mV / 31 kΩ
Frequency response	Hz 90÷20.000	90÷20.000	90÷20.000
S/N ratio	dB 81 dB / 85 dBA	81 dB / 85 dBA	81 dB / 85 dBA
<b>OUTPUTS</b>			
<b>Constant voltage outputs With double lines (A/B)</b> One zone output can be configured as a standby for the others.	2 zones for 100V lines Minimum 40 Ω	4 zones for 100V lines Minimum 40 Ω	6 zones for 100V lines Minimum 40 Ω
<b>Link</b>	2 off Rj45 for connection with another VAIE 6500-VES unit	2 off Rj45 for connection with another VAIE 6500-VES unit	2 off Rj45 for connection with another VAIE 6500-VES unit
Output level / Impedance	1 V / 400 Ω	1 V / 400 Ω	1 V / 400 Ω
Sensitivity / Input impedance	3600 mV / 3 kΩ	3600 MV / 3 KΩ	3600 MV / 3 KΩ
<b>Emergency controls</b>	Programmable for normally active or normally inactive state	Programmable for normally active or normally inactive state	Programmable for normally active or normally inactive state
Controlled inputs CONT. IN	7 off inputs with diagnostic	7 off inputs with diagnostic	7 off inputs with diagnostic
Outputs R1, R2, R3	3 relays for signalling, state of emergency and faults, N.O-N.C-Exchange state	3 relays for signalling, state of emergency and faults, N.O-N.C-Exchange state	3 relays for signalling, state of emergency and faults, N.O-N.C-Exchange state
<b>General information</b>			
Mains power supply @230VAC Consumption @230VAC	230Vca 50/60Hz +10/-15% 646 W full load (2amps active) 36 W a vuoto	230Vca 50/60Hz +10/-15% 653 W full load (2amps active / 2amp standby)	230Vca 50/60Hz +10/-15% 660 W full load (2amps active / 4amp standby) Efficiency: 75,6%
Secondary power supply @24 VDC (26,3 VDC)	20 A full load	20 A full load	20 A full load
Secondary power supply Consumption @24 VDC	0,7 A no load/ quiescent 0,2 A no load / energy saving	0,95 A no load / quiescent 0,2 A no load / energy saving	0,2 A no load / quiescent 0,2 A no load / energy saving
Batteries	It is possible to use other batteries (18 Ah - 26 Ah - 40 Ah)		
Environmental operating conditions	Temperature: +5°C ÷ +40°C Relative humidity: 25% to 75% (non-condensing)		
Type of mounting	Wall mounting	Wall mounting	Wall mounting
Dimensions (WxHxD)	mm 430x 620x240	430x 620x240	430x 620x240
Weight	Kg 19,3	19,3	19,3

# 12 | Security and emergency systems EN 54

EN 54 - 16  
0068-CPR-044/2016



## VAIE 5502

Code 41491

### WALL MOUNTING ALL-IN-ONE SYSTEM

This system is able to manage 2 alarm zones via local controls, remote microphone station and controlled inputs.

- Audio rated power: 500W freely distributed between the zones up to a maximum of 250W within a single zone.
- 4,3" touch screen back-lighted display for alert & evacuation zone selection, levels adjustment, settings and failure visualization.
- Fireman's monitored microphone on the front panel.
- Sending of evacuation and alert pre-recorded messages.
- 7 monitored inputs, each of which is configurable for the playback or either evacuation or alert messages, programmable for each zone, or for the reset of the messages.
- N.º 1 imusic input for sound sources.
- N.º 1 configurable relay output.
- Double output A+B per zone.
- Secure front panel button for operating the emergency system complete with led indicator.
- Front panel reset button.
- Possibility to source either BGM or paging announcements from microphone units.
- Possibility to connect up to 4 remote emergency microphone units FMD.
- EN54-4 certified internal battery charger for 24 Vdc power supply (batteries not included).



VAIE 5502	
<b>Code</b>	<b>41491</b>
Rated audio output @230VAC *typical distortion at 25 W 0,025%	W 500 W / D=2,5%*
Rated audio output @24VDC *typical distortion at 25 W 0,025%	W 400 W / D=10%*
Display	4.3" backlit with touch screen 480x272 pixels
N° of zones/amplifiers	2
<b>INPUTS</b>	
<b>Emergency microphone</b>	Dynamic, XLR-F on the front door
Sensitivity / Impedance	Livello segnale 20 mV / 10 k
Frequency response	Hz 60÷20.000
S/N ratio	dB 72
<b>Emergency units (EMG. DESK)</b>	1 off RJ45 for emergency microphone units (FMD range)
Sensitivity / Impedance	Signal level: max. 1400 mV / 85 k
Frequency response	Hz 60÷20.000
S/N ratio	dB 83
<b>Music</b>	Balanced with terminals (HOT-COM-GND)
Sensitivity / Impedance	134 mV / 31 k
Frequency response	Hz 90÷20.000
S/N ratio	dB 81 dB / 85 dBA
<b>OUTPUTS</b>	
<b>Constant voltage outputs With double lines (A/B)</b>	2 zones for 100V lines Load impedance for each zone ≥40 Load impedance for all zones ≥20
One zone output can be configured as a standby for the others.	
<b>Emergency controls</b>	Programmable for normally active or normally inactive stat
Controlled inputs CONT. IN	7 off inputs with diagnostic
Output R1	1 relay for signalling, state of emergency and faults, N.O-N.C-Exchange state
<b>General information</b>	
Mains power supply @230VAC Consumption @230VAC	230 Vca 50/60Hz +10/-15% 646 W full load (2amps active) 36 W no load
Secondary power supply @24 VDC (26,3 VDC) Secondary power supply Consumption @24 VDC	20 A full load 0,92 A no load / quiescent 0,3 A A no load / energy saving
Batteries	Suggested model: W-MS12/28 (26÷28 Ah). It is possible to use other batteries (18 Ah - 33 Ah - 40 Ah).
Environmental operating conditions	Temperature: +5°C ÷ +40°C. Relative humidity: 25% to 75% (non-condensing)
Type of mounting	Wall mounting
Dimensions (L x H x P)	mm 430x 620x240
Net weight (without batteries)	Kg 19,3

# 14 | Security and emergency systems EN 54

The new **VAIE 4000** range of integrated voice evacuation systems for emergency facilities, has been specifically designed for wall-mounting and equipped with control units, certified in compliance with **EN 54-16:2008 / EN 54-4** standards.

EN 54 - 16  
0068-CPR-044/2016



## VAIE 4101

Code 44605

## VAIE 4102

Code 44606

## VAIE 4251

Code 44607

## VAIE 4252

Code 44608

### WALL MOUNTING ALL-IN-ONE SYSTEM

These models are capable of managing 1 or 2 alarm zones - with an overall power of 100 or 250 W - driven by a single amplifier, as well as remote microphone stations and controlled inputs to be connected to a central fire-fighting system.

- Rated audio output: 100 W / 250 W.
- Backlit 4.3" display with touch screen for selecting the alert and evacuation zones and enabling navigation for adjusting volume levels, configuring the equipment and viewing failures.
- Handheld fireman's paging microphone.
- Sending out of pre-recorded EVACUATION and ALERT messages.
- 4 off controlled input contacts, configurable for playing the evacuation and/or alert messages to the zone, for resetting the messages or for signalling the failure of an external equipment.
- 1 off auxiliary/music input configurable as a music source, a call with precedence activation or a call with automatic activation (VOX).
- 2 off configurable relay outputs.
- Local button for placing the system in an emergency state, equipped with its own LED.
- Local button for resetting the fault acoustic signal and stopping playing out of alarm messages.
- EN54-4 certified internal battery charger unit for 24Vdc secondary power supply.
- Possibility to connect up to 4 MBT 1000 broadcasting microphone units or - as an alternative - up to 2 Series FMD 2000 remote emergency units.
- Possibility to set a standby amplifier (for VAIE 4102 and VAIE 4252 models only).
- An optional extension card can be used for broadcast general calls towards other connected units or as an additional music input.



	VAIE 4101	VAIE 4102	VAIE 4251	VAIE 4252
<b>Code</b>	<b>44605</b>	<b>44606</b>	<b>44607</b>	<b>44608</b>
Rated audio output @230VAC	W 100 W	100 W	250 W	250 W
Rated audio output @24VDC	W 85 W (THD = 10%)	85 W (THD = 10%)	200 W (THD = 10%)	200 W (THD = 10%)
Rated audio output @24VDC	W 68 W (THD = 10%)	68 W (THD = 10%)	158 W (THD = 10%)	158 W (THD = 10%)
Display	4.3", backlit with touch screen, 480x272 pixels	4.3", backlit with touch screen, 480x272 pixels	4.3", backlit with touch screen, 480x272 pixels	4.3", backlit with touch screen, 480x272 pixels
N° of zones/amplifiers	1	2	1	2
<b>INPUTS</b>				
<b>Emergency microphone</b>	Dynamic XLR-F w/P.T.T. (Push To Talk) on the front door	Dynamic XLR-F w/P.T.T. (Push To Talk) on the front door	Dynamic XLR-F w/P.T.T. (Push To Talk) on the front door	Dynamic XLR-F w/P.T.T. (Push To Talk) on the front door
Sensitivity / Impedance	Signal level: 20 mV / 10 kΩ	Signal level: 20 mV / 10 kΩ	Signal level: 20 mV / 10 kΩ	Signal level: 20 mV / 10 kΩ
Frequency response	Hz 110 ÷ 10.000	110 ÷ 10.000	110 ÷ 10.000	110 ÷ 10.000
S/N ratio	dB 61	61	61	61
<b>Paging / Emergency units (UNIT)</b>	1 off RJ45 for paging units (PA) or emergency units	1 off RJ45 for paging units (PA) or emergency units	1 off RJ45 for paging units (PA) or emergency units	1 off RJ45 for paging units (PA) or emergency units
Sensitivity / Impedance	Signal level: max. 850 mV / 8 kΩ	Signal level: max. 850 mV / 8 kΩ	Signal level: max. 850 mV / 8 kΩ	Signal level: max. 850 mV / 8 kΩ
Frequency response	Hz 60 ÷ 20.000	60 ÷ 20.000	60 ÷ 20.000	60 ÷ 20.000
S/N ratio	dB 84	84	84	84
<b>AUX INPUT (LINE VOX) / MUSIC</b>	Balanced with terminals (HOT-COM-GND) Programmable in ON / OFF / VOX with A.P.T. models Precedence input with contact closing activation	Balanced with terminals (HOT-COM-GND) Programmable in ON / OFF / VOX with A.P.T. models Precedence input with contact closing activation	Balanced with terminals (HOT-COM-GND) Programmable in ON / OFF / VOX with A.P.T. models Precedence input with contact closing activation	Balanced with terminals (HOT-COM-GND) Programmable in ON / OFF / VOX with A.P.T. models Precedence input with contact closing activation
Sensitivity / Impedance	160 mV / 40 kΩ	160 mV / 40 kΩ	160 mV / 40 kΩ	160 mV / 40 kΩ
Frequency response	Hz 40 ÷ 20.000	40 ÷ 20.000	40 ÷ 20.000	40 ÷ 20.000
S/N ratio	dB 73	73	73	73
<b>OUTPUTS</b>				
<b>Constant voltage outputs</b>	1 zone A/B for 100 V lines - Minimum 100 Ω	2 zones A/B for 100 V lines - Minimum 100 Ω	1 zone A/B for 100 V lines - Minimum 40 Ω	2 zones A/B for 100 V lines - Minimum 40 Ω
<b>Emergency controls</b>	Programmable for normally active or normally inactive state	Programmable for normally active or normally inactive state	Programmable for normally active or normally inactive state	Programmable for normally active or normally inactive state
Controlled inputs (IN1 ÷ IN4)	4 off inputs with diagnostic	4 off inputs with diagnostic	4 off inputs with diagnostic	4 off inputs with diagnostic
Outputs R1, R2	2 off relays for signalling, state of emergency and faults ( 24 Vdc / 1 A each ) N.O-N.C-Exchange state	2 off relays for signalling, state of emergency and faults ( 24 Vdc / 1 A each ) N.O-N.C-Exchange state	2 off relays for signalling, state of emergency and faults ( 24 Vdc / 1 A each ) N.O-N.C-Exchange state	2 off relays for signalling, state of emergency and faults ( 24 Vdc / 1 A each ) N.O-N.C-Exchange state
<b>GENERAL INFORMATION</b>				
Mains power supply	230 Vac 50/60 Hz +10/-15%	230 Vac 50/60 Hz +10/-15%	230 Vac 50/60 Hz +10/-15%	230 Vac 50/60 Hz +10/-15%
Consumption @230VAC	130 W full load / 22 W quiescent	130 W full load / 22 W quiescent	330 W full load / 33 W quiescent	330 W full load / 33 W quiescent
Secondary power supply	24 Vdc (2 x 12 Vdc batteries)	24 Vdc (2 x 12 Vdc batteries)	24 Vdc (2 x 12 Vdc batteries)	24 Vdc (2 x 12 Vdc batteries)
Consumption @24 VDC	4,2 A full load / 660 mA quiescent / 0,22 A energy saving	4,2 A full load / 660 mA quiescent / 0,22 A energy saving	9,8 A full load / 940 mA quiescent / 0,22 A energy saving	9,8 A full load / 940 mA quiescent / 0,22 A energy saving
Batteries	12 Ah - Ri max. 250 mOhm 18 Ah - Ri max. 167 mOhm 24 h in standby + 1/2 h full power alarm message 72 h in standby + 1/2 h full power alarm message	12 Ah - Ri max. 250 mOhm 18 Ah - Ri max. 167 mOhm 24 h in standby + 1/2 h full power alarm message 72 h in standby + 1/2 h full power alarm message	12 Ah - Ri max. 250 mOhm 18 Ah - Ri max. 167 mOhm 24 h in standby + 1/2 h full power alarm message 72 h in standby + 1/2 h full power alarm message	12 Ah - Ri max. 250 mOhm 18 Ah - Ri max. 167 mOhm 24 h in standby + 1/2 h full power alarm message 72 h in standby + 1/2 h full power alarm message
<b>Charger / Power supply unit</b>	2.5 A (I max. a) / 5 A (I max. b) 21 V (final voltage - detached battery) / 27,2 V (complete load voltage)	2.5 A (I max. a) / 5 A (I max. b) 21 V (final voltage - detached battery) / 27,2 V (complete load voltage)	9 A (I max. a) / 11 A (I max. b) 21 V (final voltage - detached battery) / 27,2 V (complete load voltage)	9 A (I max. a) / 11 A (I max. b) 21 V (final voltage - detached battery) / 27,2 V (complete load voltage)
Internal fuses	V~ 2AT / V 10AT	V~ 2AT / V 10AT	V~ 2AT / V 10AT	V~ 2AT / V 10AT
Environmental operating conditions	Temperature: +5°C ÷ +40°C / Relative humidity: 25% to 75% (non-condensing)	Temperature: +5°C ÷ +40°C / Relative humidity: 25% to 75% (non-condensing)	Temperature: +5°C ÷ +40°C / Relative humidity: 25% to 75% (non-condensing)	Temperature: +5°C ÷ +40°C / Relative humidity: 25% to 75% (non-condensing)
Type of mounting	Wall mounting	Wall mounting	Wall mounting	Wall mounting
Dimensions (WxHxD)	mm 360 x 495 x 193	360 x 495 x 193	360 x 495 x 193	360 x 495 x 193
Weight	Kg 11,5	11,5	11,5	11,5

# 16 Security and emergency systems EN 54

EN 54 - 16  
0068-CPR-001/2014

The controller **VAC 2006** is the heart of VAIE 2250 evacuation system; it has been designed to drive all the supervising functions of the entire system, in compliance with the current safety standard for voice evacuation systems. It also manage and controls all the audio signals (evacuation, alert and standard messages and background music).



## VAC 2006

Code 37712

### CONTROLLER

- Controlled emergency microphone on the front panel
- 2-channel broadcast system
- Built-in message generator to broadcast prerecorded messages (EVAC and ALERT)
- USB input for background music source
- RJ45 CAT5 connections
- 2 lines for call stations FMD range (max 16 with 7 priority levels)
- Back-up power amplifier management
- Secondary emergency power supply input (24 VDC)
- 7 controlled input contacts
- 3 relay outputs
- Graphic display 128x64 pixel monochrome, for displaying multiple windows management
- Complete diagnostic of system fault events
- Standard rack mounting 19" (2 units)

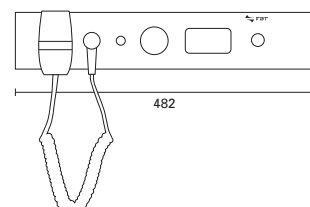
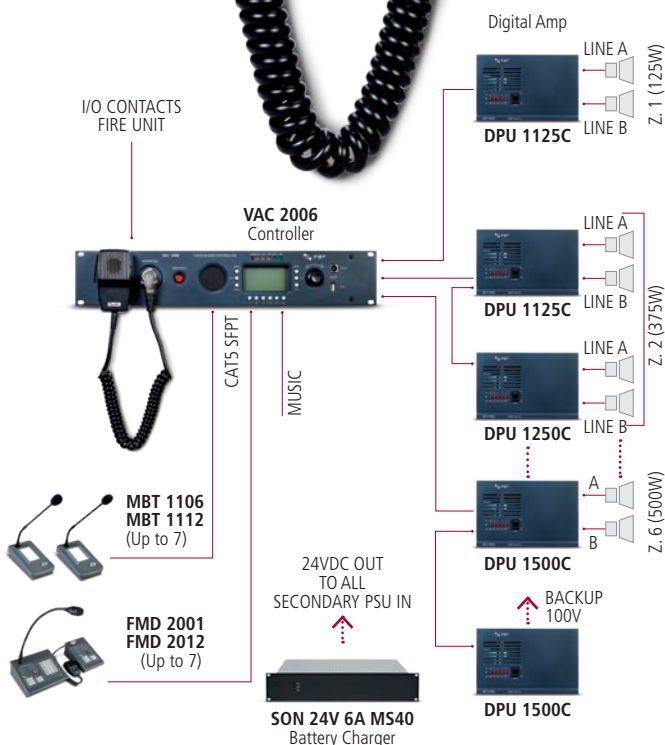



The router **VAR 2006** is the best solution for the sound systems with a very interesting compromise between price and performance

Connected to a VAIE 2250 control line, it can drive up to 6 zones with external power amplifiers (MPA5000 range) to a maximum of 1000 W. Each output line consists of 2 speaker circuits (A & B) in order to guarantee the complete area coverage also in case of one loudspeaker circuit failure. The maximum system configuration includes 6 controllers connected to 36 routers (6 for each VAIE 2250) for a total of 216 zones. The router can be used with power signals (amplifier 100 V output). Two different configurations are possible: in the first one you can connect 2 amplifiers (one for music and one for speech); in the second configuration it is possible to manage 2 voice amplifiers (3 zones each) and one music amplifier. In any case all connected amplifiers are constantly monitored and the music one can be also used as backup: in case of a failure it automatically replaces the voice amplifier.

# Security and emergency systems EN 54

EN 54 - 16  
0088-CPR-001/2014



## VAR 2006

Code 37713

### ROUTER

- 6 speakers zones with double output lines A+B
- Double input 100 V for 1 or 2 voice amplifiers (IN 1 zone 1÷3, IN 2 zone 4÷6)
- Front panel push button to switch on/off the music on each single zone
- RJ45 socket for VAIE 2250 connection
- 7 controlled input contacts
- 6 open collector outputs
- 2 relay outputs

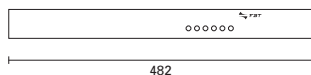
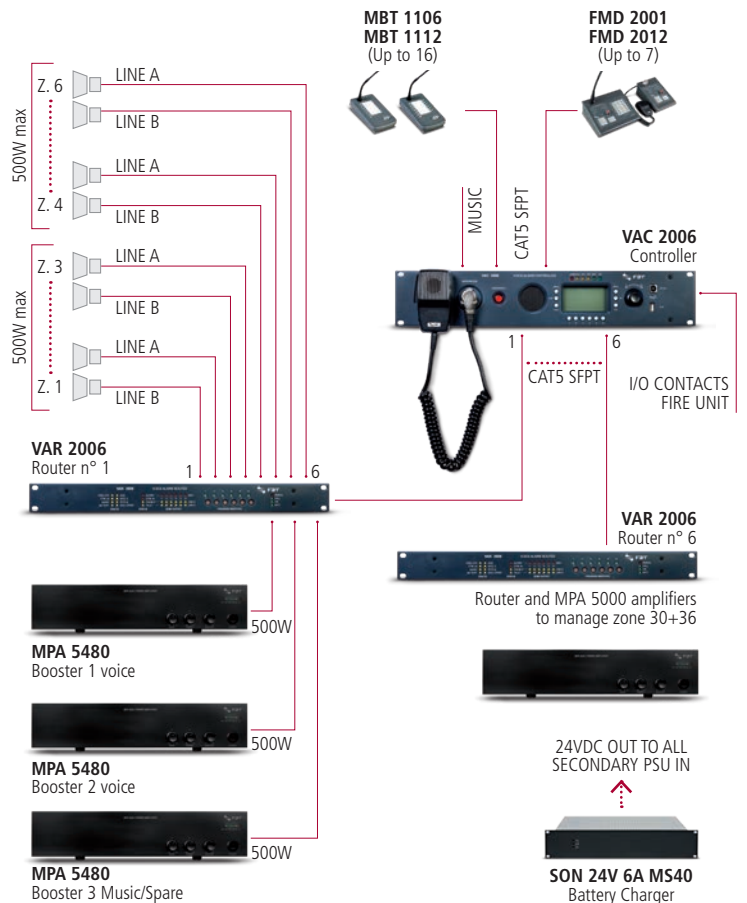

# 18 | Security and emergency systems EN 54

EN 54 - 16  
0068-CPR-001/2014



## DPU 1125 C

Code 37724

## DPU 1250 C

Code 37725

## DPU 1500 C

Code 37726

### CLASS D MODULAR AMPLIFIERS

Careful design and a choice of reliable high-tech components led to the creation of this range of extremely compact Class D amplifiers, capable of functioning even in the toughest conditions and with a minimum energy consumption. They include a diagnostics board which permits easy and rapid test of the correct unit operation and the check of the loudspeaker's line integrity. The double output circuit with a separate control (A and B) allows realizations of redundant line plants. In case of short circuit on one of the two output lines, the damaged line will automatically be disconnected to allow the regular working of the other one. The CHA 1004 (Code 37711) power card-cage enables amplifier units to be installed in a standard 19" rack. On each cage can be installed up to 4 amplifiers DPU 1125 C and/or DPU 1250 C or up to 2 amplifiers DPU 1500 C.

The DPU amplifiers have been designed to be used with the VAIE 2250 system; they can allow to develop high power zones when they are connected to the controller VAC 2006 through a shielded cable CAT5 SFTP.

A maximum of 16 DPU units can be connected to each of the six VAC 2006 output lines (zones); a backup amplifier for each group can be set.

The independent power supply of each amplifier makes this system really reliable and fully in compliance with safety standards.

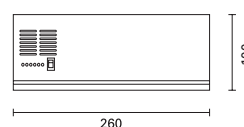
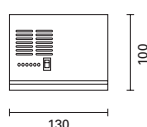
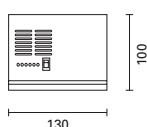



## MPA 5240

Code 37489

## MPA 5480

Code 37491

### CLASS D MODULAR AMPLIFIERS

This is a new range of power units designed specifically for professional sound-broadcasting systems with service and emergency messages. Thanks to the great reliability of the protection circuits used, combined with an attractive appearance and the very tough structures, the MPA range constitutes the ideal product for quality amplification, with a particularly interesting price/ performance ratio. If this amplifier is used in emergency systems, it is possible to disable all the front-panel controls (tone and volume controls). In this way it is possible to prevent the levels set at the time of commissioning the system from being altered accidentally.

- Balanced line input/output (XLR-F and XLR-M sockets, with adjustable sensitivity)
- Unbalanced line input (double RCA socket)
- MBT 1101 microphone station input (RJ45 socket)
- Telephone/emergency audio input for priority calls with adjustable threshold and sensitivity
- Front panel overall volume control and treble and bass controls
- Rear-panel selector switch for enabling/disabling front-panel tone and volume controls
- Constant voltage (50/70/100 V) or 8  $\Omega$  impedance loudspeaker line output.
- LED-type Vu meter for clear and immediate monitoring of output power
- Contacts for activating precedence on line input
- Alerting signal (chime) with level control
- Selectable 230/115 VAC and 24 VDC mains power supply

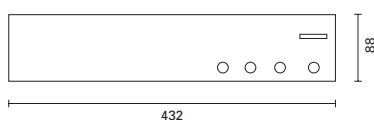

# 20 | Security and emergency systems EN 54

EN 54 - 16  
0068-CPR-001/2014



## TSC6000-EN

### AFM 2000

Wall-mounting is possible cabinet (optional).

### Code 41549



### Code 40951

#### TOUCH SCREEN MICROPHONE STATION FOR EMERGENCY CALLS

The **TSC6000-EN** touch screen remote unit allows the sending of emergency live messages and evacuation/alert pre-recorded messages.

The unit is equipped with a 7" touch screen back-lighted display for zones selection and customization, while a group of LEDs give information about the emergency system state and faults.

- Emergency key
- "Key pad" mode / "Numeric pad" mode
- Function keys to create groups of zones
- Zone labels customization
- Live emergency calls
- Broadcast calls

- Status LEDs / Fault signalling LEDs
- Pre-recorded messages recall
- Emergency messages reset
- Warning signal muting
- Possibility to connect up to 2 TSC6000-EN to a VAIE 6500 or 7500 compact system (as an alternative to FMD 2000 range units)
- Possibility to connect up to 4 TSC6000-EN to a VAC 2006 controller

The microphone is NOT included in the supply. It's possible to match with **TSC6000-EN** unit these models:

- **FMG 2000** Dynamic microphone with flexible stem
- **FMH 2000** Hand-held microphone with P.T.T key



"Key pad" mode



"Numeric pad" mode

EN 54 - 16  
0068-CPR-001/2014

The remote consoles **FMD 2012** and **FMD 2001** are fully diagnosed, and allow greater operational and management flexibility for any service and/or emergency calls and/or prerecorded messages on the zones of the system. The LEDs on the front panel provide the main information on the status of the emergency system and on any failures.

The **FMD 2001** station enables a single All-Call to be made; if the alarm messages have to be sent zones, on the other hand, it to use the **FMD 2012** a maximum of 12 zones to

to separate will be necessary station, which enables be selected.



## FMD 2001

## FMD 2012

Code 37485

Code 37486

### EMERGENCY PAGING UNITS

Each station must be completed with an additional microphone to be chosen from among the following models:

- **FMG 2000** Dynamic gooseneck microphone
  - **FMH 2000** Dynamic hand-held microphone with P.T.T. key
- According to the used system units, it is possible to set-up the PTT and AUX keys and, only for the FMD 2012, each of the 12 selection keys in order to enable selection of groups of zones (keys 1 to 12 and the PTT key) or to create a specific combination of messages for the different zones (AUX key).

It is possible to connect up to 7 remote station units in cascade formation by means of the IN/OUT sockets provided for this purpose, which can be used as inputs or outputs as required. The connections to the units are made by means of CAT5e SF/UTP shielded cable and a shielded STP connector.

- Fully diagnosed
- Emergency key
- Live emergency calls
- Sending of pre-recorded Evacuation/Alert messages
- Broadcast calls
- Zone-selection keys with status-LEDs (FMD 2012 only)
- Faults/Failures LEDs
- AUX function to call pre-set messages
- Reset of emergency messages
- Muting of the buzzer for failure detection (ACK)

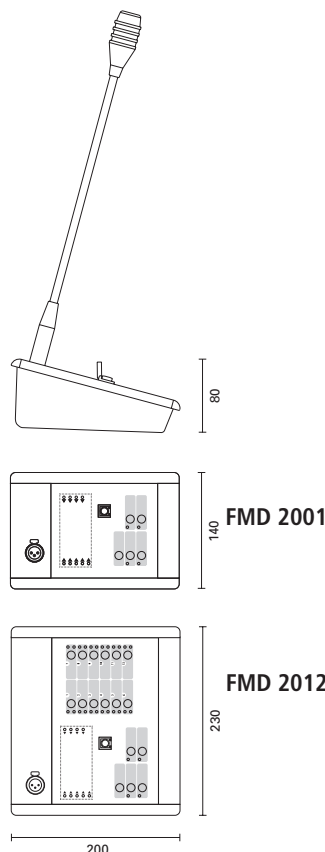

### FMG 2000

Dynamic gooseneck microphone

EN 54 - 16  
0068-CPR-001/2014

Code 37488

### FMH 2000

Dynamic hand-held microphone

EN 54 - 16  
0068-CPR-001/2014

Code 37487

### MBT

Model	Code
MBT 1112E	37494
MBT 1106	37492
MBT 1112	37493

Standard paging units can be used in the Voice Evacuation Systems.



## 22 Security and emergency systems EN 54



	<b>TSC 6000-EN</b>		<b>FMD 2001</b>		<b>FMD 2012</b>	
<b>Code</b>	<b>40951</b>		<b>37485</b>		<b>37486</b>	
No. of selectable zones	1 ÷ 216 (from 20 to 60 zone selection keys + 6 function keys)		1		12	
Typical output level	mV	300	300		300	
Frequency response	Hz	20÷20.000	130÷19.000		130÷19.000	
Distortion		>1%	>1%		>1%	
LOW CUT filter		-10dB/100Hz	-3dB/380Hz		-3dB/380Hz	
S/N ratio	dB	>60	>60		>60	
Connection		RJ45 (IN/OUT)	RJ45 (IN/OUT)		RJ45 (IN/OUT)	
Power supply voltage	Vcc	24	24		24	
Maximum absorption @24Vcc	mA	165	60		130	
Dimensions (WxHxD)	mm	230x80x200	140x80x200		230x80x200	
Net weight	Kg	1,6	0,77		1,55	



	<b>DPU 1125 C</b>		<b>DPU 1250 C</b>		<b>DPU 1500 C</b>	
<b>Code</b>	<b>37724</b>		<b>37725</b>		<b>37726</b>	
Rated output power @230 VAC	W RMS	125	250		500	
Power outputs	V	100	100		100	
Distorsion at rated power		< 1%	< 1%		< 1%	
Input		Double RJ45, In/Out audio/RS485 from VAC 2006	Double RJ45, In/Out audio/RS485 from VAC 2006		Double RJ45, In/Out audio/RS485 from VAC 2006	
Frequency response	Hz	80-20.000 Hz	80-20.000 Hz		80-20.000 Hz	
Low Cut filter (- 3 dB)	Hz	330 Hz	330 Hz		330 Hz	
Mains power supply		230 Vac ± 10% - 50/60 Hz / 24 Vdc	230 Vac ± 10% - 50/60 Hz / 24 Vdc		230 Vac ± 10% - 50/60 Hz / 24 Vdc	
Power consumption 230 Vac		200 W (240 VA)	400 W (480 VA)		800 W (960 VA)	
Power consumption 24 Vdc	A	4.6	9		17	
19" rack mounting		CHA1004 optional basket unit (H: 3U + 1U for support brackets)	CHA1004 optional basket unit (H: 3U + 1U for support brackets)		CHA1004 optional basket unit (H: 3U + 1U for support brackets)	
Installable quantity for each CHA 1004		4	4		2	
Dimensions (WxHxD)	mm	100x130x395	100x130x395		200x130x395	
Weight	Kg	6	9		18	



	<b>MPA 5240</b>	<b>MPA 5480</b>
<b>Code</b>	<b>37489</b>	<b>37491</b>
Rated output power	W 240	480
Constant voltage output / low impedance output	V 100-70-50 / 8 Ω	100-70-50 / 8 Ω
Tones control	dB Bass ± 10 (100 Hz) - Treble ± 10 (10 kHz)	Bass ± 10 (100 Hz) - Treble ± 10 (10 kHz)
<b>In UNITS</b>	RJ45 (MBT 1101)	RJ45 (MBT 1101)
Sensitivity / Impedance	mV 320	320
S/N Ratio	db > 78	> 78
Frequency response	Hz 30 ÷ 20.000	30 ÷ 20.000
Number of consoles MBT 1101	Max 6 consoles in daisy chain max distance 200 mt	Max 6 consoles in daisy chain max distance 200 mt
<b>Line input</b>	Balanced XLR, Unbalanced RCA	Balanced XLR, Unbalanced RCA
Sensitivity / Impedance	mV 300 / 60 KΩ	300 / 60 KΩ
S/N Ratio	db > 77	> 77
Frequency response	Hz 30 ÷ 20.000	30 ÷ 20.000
<b>Telephone input</b>	Balanced with priority activation	Balanced with priority activation
Sensitivity / Impedance	mV 120 / 6 KΩ	120 / 6 KΩ
S/N Ratio	db > 75	> 75
Frequency response	230 ÷ 13.000	230 ÷ 13.000
Line OUT	Balanced, XLR	Balanced, XLR
Power supply	230/115 Vca - 50/60 Hz /24 Vcc	230/115 Vca - 50/60 Hz /24 Vcc
Mains power supply	W 535 (610 Va)	1160 (1330 Va)
External DC power supply	A 13,2 / 0,2	33 / 0,8
Rack dimensions 19"	Optional bracket RMK 5000	Optional bracket RMK 5000
Dimensions (LxHxP)	mm 432X88X272	432X88X272
Weight	Kg 10,5	16

# 24 | Wall-mounting speakers EN 54

EN 54 - 24  
0068-CPR-040/2013



## WSP 406 TWB/EN

Code 40958

### WALL-MOUNTING SPEAKERS

The speaker units of the WSP range, featuring a refined and modern design and ideal for both background music and speech, have been designed specifically for schools, hospitals, waiting rooms, hotels, shops, offices and restaurants. They can be either wall-mounted or ceiling-mounted. The housing is made of white self-extinguishing ABS (UL94-V0) with a metal front grille. Each unit has a ceramic terminal block and a thermal fuse. The bi-directional WSP 406 TWB/EN speaker units is suitable in particular for installing in transit areas and corridors.

The models with the suffix -EN were designed specifically for use in emergency and evacuation systems (VES). They are certified for compliance with EN 54-24:2008.

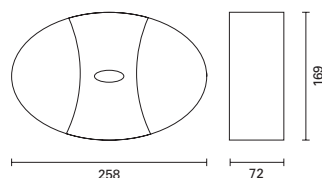

## WSP 406 T/EN

Code 37729

### WALL-MOUNTING SPEAKERS

The WSP 406 T/EN speakers, with elegant and discrete design, are specifically aimed at schools, hospitals, waiting rooms, hotels, where both music and speech have to be heard by customers. Can be mounted in any position on a wall or ceiling. Self-extinguishing ABS (UL94-V0) body with metal front grille. Ceramic bloc.

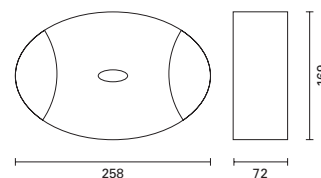





### WMS 406 T/EN

Code 37730

#### WALL-MOUNTING SPEAKERS

WMS 406 T/EN speakers have been designed as surface or ceiling-mounted units for a wide area of applications. Thanks to their steel casings the speakers are tough to vandals and more resistant to any and all mechanical damages. They are equipped with ceramic terminal block and thermal fuse that ensure continuous operations of sound transmitting line connected with the loudspeaker even in the case the latter is damaged or burnt as a result of fire.

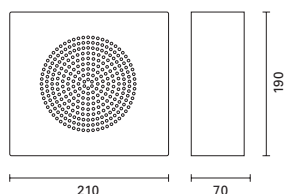

### RWS 412 T/EN

Code 37731

#### FLUSH-MOUNTING WALL/CEILING SPEAKERS

The ideal applications for **RWS 412 T/EN** speaker units are in hospitals, hotels, offices, schools, shops and whenever flush-mounting with a discreet and elegant aesthetic impact is required. Made of self-extinguishing plastic material to UL94-V0 with a front metal grille, they are available with a line transformer. Ceramic block and temperature limit fuse are installed inside the loudspeaker. A metal box for flush mounting enables easy and rapid wall or ceiling mounting.

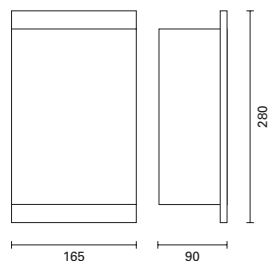

# 26 | Wall-mounting speakers EN 54

EN 54 - 24  
0068-CPR-040/2013



## CSP 406 T/EN

Code 37727

### IN-CEILING SPEAKERS

The **CSP 406 T/EN** and **CSP 412 T/EN** speaker units, suitable for mounting in false ceilings, ensure excellent reproduction of both speech and music. Made of stamped metal sheeting treated with white scratchproof and non-reflecting paint, they will fit elegantly into any environment. Each unit consists of a load-bearing ring with quick-fitting hooks with springs for easy securing to the ceiling. The central mask with the loudspeaker cabled to the line transformer fits into the ring with a handy turning movement. According to the specification of the EN 54-24 voice evacuation system, this range of speakers has a double-galvanized steel flameproof cap, combined with ceramic input/output terminal strips, a thermal fuse and a ground termination. The built-in transformer enables connection to constant-voltage lines at 100, 70 and 50V with the adjustable outputs.

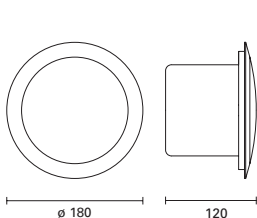

## CSP 412 T/EN

Code 37728

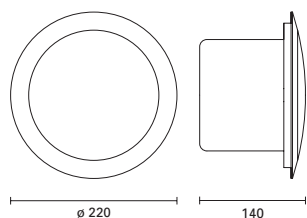

## MHO 420 T/EN

Code 37735

### HORN SPEAKER

The **MHO 420 TW/EN** horn type speaker units are particularly well suited for outdoor use, even in difficult weather conditions. They feature a watertight construction and a high level of weatherproofing. The body is made of die-cast aluminium while the screws and brackets are made of stainless steel. The horn is made of aluminium sheeting. Each model has a line transformer and a rear switch for selecting the operating output (5 steps).

The **MHO 420 TW/EN** has been designed to be used in security installations and has a thermal fuse which excludes the speaker in case of overheating, a ground connector and a flame resistant connecting cable (80 cm long).

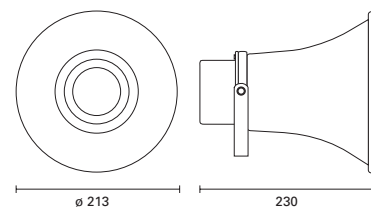



		<b>WSP 406 TWB/EN</b>	<b>WSP 406 T/EN</b>	<b>WMS 406 T/EN</b>	<b>RWS 412 T/EN</b>	<b>CSP 406 T/EN</b>	<b>CSP 412 T/EN</b>	<b>MHO 420 TW/EN</b>
<b>Code</b>		<b>40958</b>	<b>37729</b>	<b>37730</b>	<b>37731</b>	<b>37727</b>	<b>37728</b>	<b>37735</b>
Adjustable power	W	6 / 3 / 1,5	6 / 3 / 1,5	6 / 3 / 1,5	12 / 6 / 3	6 / 3 / 1,5	12 / 6 / 3	20 / 15 / 10 5 / 2,5
Speakers		2 broadband	1 broadband	1 broadband	1 broadband	1 dual cone broadband	1 dual cone broadband	Complete with driver unit
Sound press. SPL Pnom/1m	dB	93	96	98	99	99	105	123
Sensivity 1W/1m	dB	86	89	91	89	92	95	110
Frequency response		170÷16.000	150÷10.000	120÷15.000	150÷15.000	100÷15.000	80÷20.000	160÷10.000
Dispersion angle @2kHz		120°	150°	130°	120°	150°	130°	80°
Installation hole	mm	-	-	-	-	ø 160 ÷ 165	ø 200 ÷ 205	-
Colour	RAL	White	White	White	White	White	White	Light grey
Protection degree		-	-	-	-	-	-	IP 65
Installation		Wall and ceiling with screw	Wall and ceiling with screw	Wall and ceiling with screw	Box for flush mounting wall/ceiling	Spring fixing system	Spring fixing system	Adjustable brackets and fire resistant cable included
Dimensions (WxHxD)	mm	258x169x72	258x169x72	210x190x70	165X280X90	ø180x120	ø220x140	ø 213x230
Weight	Kg	0,95	0,8	1,6	2	1,5	1,7	1,8

# 28 | Sound Projector EN 54

EN 54 - 24  
0068-CPR-040/2013



## MSP 420 TW/EN

Code 37734

### SOUND PROJECTORS

Aluminium alloy housing and hot galvanised steel front grille. Due to its very sturdy and waterproof construction it is specially designed for industrial halls, warehouses, as well as open spaces exposed to outdoor weather conditions. Equipped with broadband loudspeaker to ensure excellent sound reproduction, adjustable sliding mounting bracket and a line transformer 100/70/50 V to set power output 20- 10-5 W. The MSP 420 0TW/EN speakers include a thermal fuse which excludes the speaker in case of overheating and a flame resistant connecting cable (80 cm long).

## MSP 420 TWB/EN

Code 40957

### SOUND PROJECTORS

#### **Vandal-proof sound projectors for voice alarm systems, 20W (10+10W)**

The **MSP 420 TWB/EN** vandal-proof sound projectors, characterised by an aluminium alloy housing and steel front grille, are fitted with fireproof cable according to UNI 9795 2010 (length 80 cm). These speaker units have been developed specifically for use in emergency and evacuation systems (VES). They are equipped with two loudspeakers and provided with a fixed bracket for wall-mounting. The power output is adjustable by means of a switch placed in the lower side of the speaker. The watertight construction and the materials adopted make them suitable to be used outdoor or in particularly damp places (swimming-pools, etc.).

EN 54 - 24

0068-CPR-040/2013



## SOP 540 T/EN

Code 40956

### SOUND PROJECTORS

These sound projectors, characterised by an ABS housing and steel front grille, are fitted with fireproof cable according to UNI 9795 2010 (length 80 cm). The fixing system makes mounting easy and enables the speaker unit to be turned in the best direction. These speaker units have been developed specifically for use in emergency and evacuation systems (VES) and each has its own ceramic terminal strip and thermal fuse. These ensure the protection of the line connecting the loudspeakers if a fire puts one or more of the speaker units connected to it out of use.

## SOP 412 T/EN

Code 37733

### SOUND PROJECTORS

Thanks to use of excellent wide band speakers, the **SOP 412 T/EN** and **SOP 426 TB/EN** units prove to be suitable for both music and speech applications. The speakers are enclosed in white cylindrical casings made of V0 self-extinguishing ABS (UL94-V0) and equipped with adjustable swiveling bracket for easy installation, wall or ceiling. Designed to achieve directional characteristic of sound emission they are mostly applied on circulation routes, corridors and in the wide areas. Each model includes a line transformer, a thermal fuse which excludes the speaker in case of overheating and a flame resistant connecting cable (80 cm long).

## SOP 426 T/EN

Code 37732

# 30 | Sound Projector EN 54

EN 54 - 24  
0068-CPR-040/2013



## MSH 15HF/EN

Code 40952

### HORN SPEAKER

High-Fidelity horn speaker, two-way, 15 W

**MSH 15HF/EN** horn-speakers are fitted with fireproof cable according to UNI 9795 2010 (length 80 cm). The fixing system makes mounting easy and enables the speaker unit to be turned in the best direction. These speaker units have been developed specifically for use in emergency and evacuation systems (VES).

These horns are two-way speaker units featuring high efficiency, an extensive response range and good power resistance. The design and materials used enable it to be employed for outdoor applications up to class of protection IP44 at the most.

The special shape of these speakers gives rise to practically constant and controlled coverage of the audio spectrum reproduced, with particularly high sensitivity.





		<b>MSP 420 TW/EN</b>	<b>MSP 420 TWB/EN</b>	<b>SOP 540 T/EN</b>	<b>SOP 412 T/EN</b>	<b>SOP 426 TB/EN</b>	<b>MSH 15HF/EN</b>
<b>Code</b>		<b>37734</b>	<b>40957</b>	<b>40956</b>	<b>37733</b>	<b>37732</b>	<b>40952</b>
Adjustable power	W	20 / 10 / 5	20 / 10 / 5	40 / 20 / 10	12 / 6 / 3	12 / 6 / 3	15 / 8 / 4
Material		Aluminium, galvanised steel front grill	Alluminio, griglia in acciaio inox	ABS, griglia in acciaio	ABS UL94-VD	ABS UL94-VD	-
Speakers		1 broadband	2	-	1 broadband	2 broadband	-
Sound press. SPL Pnom/1m	dB	103	100	104	99	96	-
Sensitivity 1W/1m	dB	90	87	88	89	89	98
Frequency response		150÷15.000	150÷15.000	100÷19.000	180÷15.000	170÷12.000	160÷20.000
Dispersion angle @2kHz		90°	Or. 2X140° Ver. 2X130°	90°	160°	140°	Or. 30° Ver. 60°
Colour	RAL	Silver, black grill	White	White	White	White	White
Protection degree		IP 65	IP 65	IP 65	IP 44	IP 44	IP 44
Installation		Adjustable brackets and fire resistant cable included	Wall mounted bracket	Adjustable swivelling bracket and fire resistant cable included	Adjustable swivelling bracket and fire resistant cable included	Adjustable swivelling bracket and fire resistant cable included	Wall mounted bracket
Dimensions (WxHxD)	mm	180x145x178	180x145x178	ø 200x220	ø 140x207	ø 140x207	355x240x315
Weight	Kg	2,4	2,9	3	1,4	1,85	4,2

# Column Speaker EN 54

EN 54 - 24  
0068-CPR-040/2013

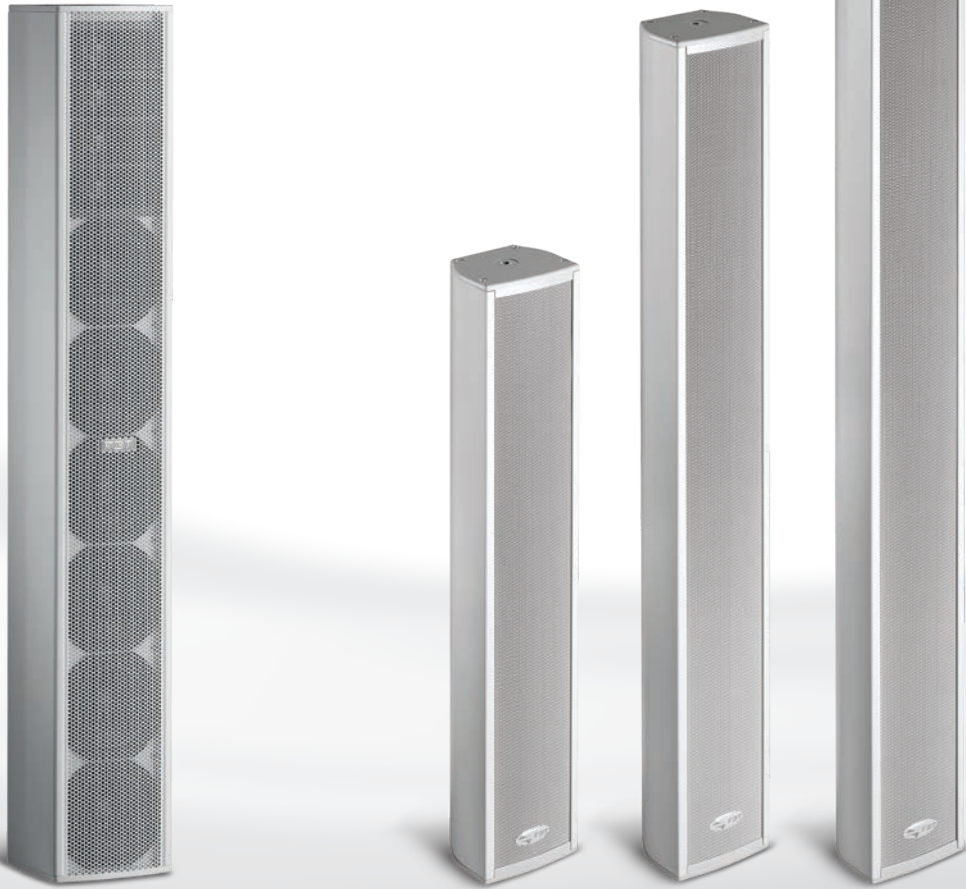

## VERTUS CLA 604

Code 36145

### PASSIVE COLUMN LINE ARRAY

- 500W 8ohm 123dB SPL
- 2-way passive column line array
- 6 x 100mm (4") custom woofer with 25mm (1") voice coil
- 4 x 25mm (1") dome neodymium tweeter on a waveguide
- Frequency response from 130Hz to 20kHz
- 100V transformer with 2 levels of power, 100 and 200W
- 100°H x 20°V dispersion
- 4-pole Euroblock input connector: 8ohm - 100W/100V - 200W/100V
- Extruded-aluminum powder-coated cabinets
- Wall-mount installation bars are supplied
- Expandable line array by adding CLA604 modules in order to increase SPL and reduce the vertical radiation lobe width
- Ideal for fixed installation in reverberant environments, it can improve both music and voice intelligibility by improving direct/reflected sound quality

## CS 4120/EN CS 4130/EN CS 4140/EN

Code 40953

Code 40954

Code 40955

### COLUMN SPEAKERS

Sound column for voice alarm systems, 20 W

The new columns of the **CS 4100** range feature loudspeakers with a broad response range and high-efficiency tweeters enabling perfect intelligibility of speech and accurate reproduction of music.

These speaker units have been developed specifically for use in emergency and evacuation systems (VES) and each has its own ceramic terminal strip and thermal fuse. These ensure the protection of the line connecting the loudspeakers if a fire puts one or more of the speaker units connected to it out of use. This speaker units are fitted with fireproof cable according to UNI 9795 2010 (length 80 cm). These columns can be turned in any direction thanks to the S4-B swivel joint included in the supply.





		<b>Vertus CLA 604</b>	<b>CS 4120/EN</b>	<b>CS 4130/EN</b>	<b>CS 4140/EN</b>
<b>Code</b>		<b>36145</b>	<b>40953</b>	<b>40954</b>	<b>40955</b>
Configuration	vie	2 way	-	-	-
Loudspeaker		-	4 + 1 tweeter	6 + 1 tweeter	7 + 1 tweeter
Rated output	W RMS	100 W (28 V / 8 Ohm)	20 W (100 V)	30 W (100 V)	40 W (100 V)
Adjustable power	W	-	20 - 10 - 5	30 - 15 - 7,5	40 - 20 - 10
Nominal impedance	W	8 Ohm (100 W)	-	-	-
Nominal impedance 100V line	W	100 Ohm (100 W) 200 Ohm (50 W)	-	-	-
Sensitivity	V/W	91 dB (1W, 1m)	92 dB (1W/1m)	93 dB (1W/1m)	93 dB (1W/1m)
Max sound pressure SPL	ohm	110 dB (1W, 1m)	105 dB (20W/1m)	108 dB (30W/1m)	109 dB (40W/1m)
Frequency response	6dB	140Hz - 20KHz (-6dB)	180÷16.000	180÷16.000	150÷14.000
Low frequency woofer	mm	6 x 100 mm / 6 x 4"	-	-	-
High frequency driver	mm	4 x 25 mm / 4 x 1"	-	-	-
Angle of dispersion (O) (-6dB)	dB	200° (500Hz) 190° (1kHz) 120° (2kHz) 110° (4kHz)	360° (500 Hz) 200° (1 kHz) 150° (2 kHz) 90° (4 kHz)	360° (500 Hz) 210° (1 kHz) 150° (2 kHz) 90° (4 kHz)	360° (500 Hz) 200° (1 kHz) 140° (2 kHz) 100° (4 kHz)
Angle of dispersion (V) (-6dB)	dB	70° (500Hz) 40° (1kHz) 15° (2kHz) 30° (4kHz)	130° (500 Hz) 75° (1 kHz) 35° (2 kHz) 20° (4 kHz)	90° (500 Hz) 40° (1 kHz) 20° (2 kHz) 20° (4 kHz)	85° (500 Hz) 30° (1 kHz) 20° (2 kHz) 85° (4 kHz)
Operating / Storage temperature	HxV	-25°C + +55°C/ -40°C + +70°C	-25°C + +55°C/ -40°C + +70°C	-25°C + +55°C/ -40°C + +70°C	-25°C + +55°C/ -40°C + +70°C
Relative umidity	kHz	<95%	<95%	<95%	<95%
Net dimensions (WxHxD)	mm	130x849x130	95x80x520	95x80x725	95x80x890
Net weight	Kg	8	3.5	4.8	5.65

# Column Speaker EN 54

EN 54 - 24

IP55 

Bringing new coverage options to the installed sound market, the new VERTUS CLA (Column Line Array) range will receive its official launch at Frankfurt Pro Light + Sound 2018. Boasting **EN54-24 certification and an IP55 rating**, the range has been created to add discreet but powerful sound reinforcement in even the most challenging of projects, including the ability to select dispersion angles depending on the project's requirements.



## Vertus CLA 803T

## Vertus CLA 403T

### VT-F 3



**Code 41795**  
**Code 41820 WHITE**  
Flying bar for CLA 803 and CLA 403

### VT-J 3



**Code 41794**  
**Code 41819 WHITE**  
Joint bar 0°-15° for CLA 803 and CLA 403

### VT-W 3



**Code 41797**  
**Code 41821 WHITE**  
Directional wall mount for CLA 803 and CLA 403 in vertical

### VT-HW 3



**Code 41798**  
**Code 41822 WHITE**  
Directional wall mount for CLA 803 and CLA 403 in horizontal

### Code 41806 - White 41823

IP55, EN54-24 COLUMN LINE ARRAY  
240W - 119 / 122dB SPL

- Passive column array
- **8 x 3" full-range custom woofers with 0.7" voice-coils**
- Frequency response from **140Hz to 20KHz**
- Vertical dispersion angle selector: **110° H x 15° V (NARROW), 110° H x 40° V (WIDE)**
- Ceramic screw-in connector with thermal fuse
- **100V / 120W** line transformer with power selector (excludable)
- Extruded aluminum cabinet with powder coating
- Grille with hydrophobic fabric
- Wide availability of accessories for installation
- Multiple CLA 803 and CLA 403 columns can be linked to increased SPL and coverage
- **IP55 rating** means suitable for outdoor installation
- **EN54-24 certification** means suitable for emergency and evacuation systems
- Ideal for fixed installations in reverberant environments where requiring heightened intelligibility of both music and voice

### Code 41807 - White 41824

IP55, EN54-24 COLUMN LINE ARRAY  
120W - 116 / 119dB SPL

- Passive column array
- **4 x 3" full-range custom woofers with 0.7" voice-coils**
- Frequency response from **140Hz to 20KHz**
- Vertical dispersion angle selector: **110° H x 25° V (NARROW), 110° H x 50° V (WIDE)**
- Ceramic screw-in connector with thermal fuse
- **100V / 60W** line transformer with power selector (excludable)
- Extruded aluminum cabinet with powder coating
- Grille with hydrophobic fabric
- Wide availability of accessories for installation
- Multiple CLA 803 and CLA 403 columns can be linked to increased SPL and coverage
- **IP55 rating** means suitable for outdoor installation
- **EN54-24 certification** means suitable for emergency and evacuation systems
- Ideal for fixed installations in reverberant environments where requiring heightened intelligibility of both music and voice

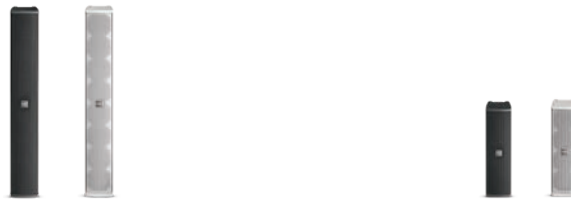

		<b>CLA 803T</b>		<b>CLA 403T</b>	
<b>Code</b>		<b>41806 - White 41823</b>		<b>41807 - White 41824</b>	
Configuration	way	1		1	
Rated noise power (100hrs)	W Vrms	100 / 28.2		50 / 28.2	
Recommended amplifier	W rms	200		100	
Nominal impedance	Ohm	8		16	
Nominal impedance (100v line)	Ohm/W	200 / 100 400 / 50		85 / 50 166 / 25	
Sensitivity (@1w/1m )	@-dB	94		91	
Max sound pressure SPL (@1m/4m )	@-dB	112 / 100		106 / 94	
Frequency response (@ -6db )	@-dB	150 Hz - 20kHz		150 Hz - 20kHz	
Fullrange driver	inch	8 x 3" / 0.75" coil		4 x 3" / 0.75" coil	
Dispersion horizontal (-6db) Narrow = wide setting	dB/Hz	500Hz - 360° 1kHz - 170° 2kHz - 125° 4kHz - 125° 8kHz - 100°		500Hz - 360° 1kHz - 170° 2kHz - 125° 4kHz - 125° 8kHz - 100°	
Dispersion vertical (-6db) Wide setting	dB/Hz	500Hz - 70° 1kHz - 35° 2kHz - 26° 4kHz - 26° 8kHz - 20°		500Hz - 160° 1kHz - 70° 2kHz - 36° 4kHz - 22° 8kHz - 20°	
Dispersion vertical (-6db) Narrow setting	dB/Hz	500Hz - 70° 1kHz - 35° 2kHz - 18° 4kHz - 10° 8kHz - 10°		500Hz - 160° 1kHz - 70° 2kHz - 28° 4kHz - 14° 8kHz - 9°	
Input connectors		Ceramic terminal block		Ceramic terminal block	
Operating / storage temperature		25°C ÷ +55°C / -40°C ÷ +70°C		25°C ÷ +55°C / -40°C ÷ +70°C	
Relative umidity	%	< 95		< 95	
Net dimensions (wxhxd)	mm/ inch	100x704x125 - 3.93x27.69x4.92		100x368x125 - 3.93x14.48x4.92	
Transport dimensions (wxhxd)	mm/ inch	160x760x180 - 6.29x29.92x7.08		160x420x180 - 6.29x16.53x7.08	
Net weight	kg/lb	5.5 / 12.12		3 / 6.61	
Transport weight	kg/lb	6.2 / 13.66		3.5 / 7.71	

# CONSTANT CURVATURE LINE ARRAY - POINT SOURCE

## Shadow

### FBT LOOKS TO ITS SHADOW WITH FIRE RESISTANT UPGRADES

FBT's renowned all-weather **SHADOW** series of enclosures is benefiting from significant upgrades that will make the range suitable for use in emergency and evacuation applications. Now offering full **EN54-24 certification** as well as a new rotomoulded enclosure in polypropylene with 5VB flame resistance classification, the newly updated series will be showcased at Frankfurt Pro Light + Sound 2018.

Suitable for use both indoors and outdoors, the **SHADOW** series was originally launched to provide **IP55**-rated extreme water and particle resistance (including a water-stop grille) in both point source and line array formats. The original IP55 series will continue to be manufactured by FBT, to cover all-weather installations not requiring the **EN54-24 certification**.

**Now the upgraded range delivers enhanced options for systems integrators with the possibility of using a single system for both weather resistant sound reinforcement and voice alarm / evacuation functions.**

All of the new **SHADOW** series enclosures are internally equipped with ceramic terminal blocks and thermal fuses, ensuring the continued operation of loudspeakers in the event of a fire.

In addition, all connections use flame-retardant cabling which adheres to the EN50200 standard (with IP68 airtight cable glands).

Upgraded point source models in the range include the extremely compact 5" **SHADOW 105T**, outputting 200W and 110 dB (peak) with a frequency response of 100Hz to 18KHz and 100° x

70° dispersion. The 8" **SHADOW 108CT** is rated at 600W / 121 dB (peak) with a 94Hz - 20KHz frequency response and 90° conical dispersion. The multipurpose coax **SHADOW 112CT** delivers 800W / 126 dB (peak) with 80° conical coverage and a frequency response of 68Hz - 20KHz.

Finally, the **SHADOW 112HC** is a 12" coaxial horn for medium to long-throw applications with an 800W rating, 129 dB SPL (peak), a frequency response of 98Hz - 19KHz and 80° x 50° dispersion. An arrayable version, the **SHADOW 142L** is also available, with each module producing 1,200W / 132 dB with a 63Hz - 20KHz frequency range and tight 80° x 15° coverage.

All of the enclosures within the **SHADOW** range are equipped with a standard 100V line transformer except for the **142L**.



# Constant Curvature Line Array Point Source

37

EN 54 - 24

IP55

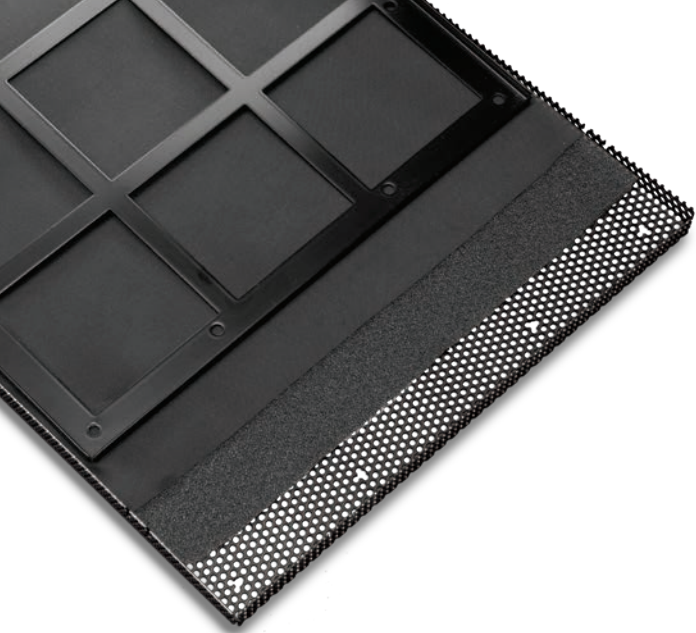

## Shadow 142L/EN

Code 41881

14" LINE ARRAY SPEAKER SYSTEM  
600W / 8ohm - 132DB SPL

- 14" woofer with a 3" coil
- HF section with two BEM optimized waveguide to 2x1.4" driver with a 2.5" coil for smooth, wide dispersion
- Sturdy molded polypropylene curved enclosure, full UV protection
- Water-stop grill with 3 layers of protection
- 80° x 15° coverage
- 7.5° or 15° adjustable angle
- IP55 weather resistant
- EN54-24 certified

## Shadow 112HCT/EN

Code 41810

HIGH PERFORMANCE 12" COAX HORN  
LOADED, MEDIUM/LONG THROW  
400W/8ohm - 129DB SPL

- 12" woofer with 2.5" coil horn loaded
- Constant directivity horn 1" HF driver with 1.7" coil
- An optional transformer model, SHADOW 112HCT, is also available with 200W/100W power tapping selection
- 80°x50° coverage
- 4 wires cable to select the desired power tapping
- Sturdy molded polypropylene curved enclosure
- Water-stop grill with 3 layers of protection
- Steel U bracket and other included hardware accessories
- IP55 weather resistant
- EN54-24 certified

SW-F 142

Flying bar



Code 36350

For rigging SHADOW 142 L

# 38 | Constant Curvature Line Array Point Source

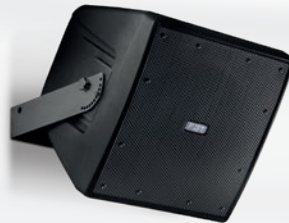

## Shadow 112CT/EN

Code 41809

MULTIPURPOSE HIGH PERFORMANCE  
12" COAX  
400W/8ohm - 126dB SPL

- 12" coaxial woofer with 2.5" coil and 1" HF driver with 1.7" coil on conical 80° horn
- 100V line transformer with selectable 200W/100W power tapping
- Sturdy molded polypropylene curved enclosure
- 4 wires cable to select the desired power tapping
- Water-stop grill with 3 layers of protection
- IP55 weather resistant
- EN54-24 certified

## Shadow 108CT/EN

Code 41808

MULTIPURPOSE  
8" COAX  
300W/8ohm - 121dB SPL

- 8" coaxial woofer with 2" coil and 1" HF driver with 1.4" coil on conical 90° horn
- 100V line transformer with selectable 100W/50W power tapping
- Sturdy molded polypropylene curved enclosure
- Steel U bracket and other included hardware accessories
- 4 wires cable to select the desired power tapping
- Water-stop grill with 3 layers of protection
- IP55 weather resistant
- EN54-24 certified

## Shadow 105T/EN

Code 40646

MULTIPURPOSE 5" FULL RANGE  
100W/8ohm - 110dB SPL

- 2 way configuration with an high power 5" cone and 1" dome for high frequencies
- 100V line transformer with selectable 50W/25W power tapping
- 100°x70° coverage
- Die-cast aluminum wall bracket with ball/socket for multi angle adjustment capability, with a security cable
- 4 wires cable to select the desired power tapping
- Water-stop grill with 3 layers of protection
- IP55 weather resistant
- EN54-24 certified

# Constant Curvature Line Array Point Source



		<b>142L/EN</b>	<b>112HCT/EN</b>	<b>112CT/EN</b>	<b>108CT/EN</b>	<b>105T/EN</b>
<b>Code</b>		<b>41881</b>	<b>41810</b>	<b>41809</b>	<b>41808</b>	<b>40646</b>
Configuration	way	2	2	2	2	2
Rated noise power 100 hrs (Voltage)	W(V)	250 (44.5)	250 (44.5)	200 (40)	150 (33.5)	50 (20)
Nominal impedance (Biamp LF / HF)	Ohm	8 (8 / 8 optional)	8	8	7,5	8
Nominal impedance 100V line	Ohm	/	50 (200)	50 (200)	85 (120)	200 (50)
	Ohm	/	100 (100)	100 (100)	166 (60)	400 (25)
Sensitivity (@1W/1m) (Biamp LF/HF)	dB	102	101	97.5	94	87.5
Maximum SPL 1m / 4m	dB	126 / 114	123 / 111	120 / 108	115 / 103	104 / 92
Frequency response	@-6dB	63Hz - 20KHz	98Hz - 19KHz	68Hz - 20KHz	94Hz - 20KHz	100Hz - 18KHz
Low frequency woofer	inch	14 - 3 coil	12 - 2.5 coil	12 - 2.5 coil	8 - 2 coil	5 - 1 coil
High frequency driver	inch	2 x 1.4 - 2.5 coil	1 - 1.7 coil	1 - 1.7 coil	1 - 1.4 coil	1 - dome
Dispersion Horizontal (-6dB)	500Hz	100°	100°	100°	160°	180°
	1Khz	55°	50°	90°	100°	140°
	2Khz	70°	60°	80°	90°	80°
	4Khz	70°	70°	50°	80°	95°
Dispersion Vertical (-6dB)	500Hz	100°	100°	100°	160°	160°
	1Khz	70°	50°	90°	100°	110°
	2Khz	30°	80°	80°	90°	70°
	4Khz	15°	50°	50°	80°	40°
Operating / Storage Temperature		-25°C to +55°C -40°C to +70°C	-25°C to +55°C -40°C to +70°C	-25°C to +55°C -40°C to +70°C	-25°C to +55°C -40°C to +70°C	-25°C to +55°C -40°C to +70°C
Relative umidity		<95%	<95%	<95%	<95%	<95%
Crossover frequency	kHz	1.2 (opt Bi-Amp)	1.6	1.6	1.8	3
Recommended HP filter		40hz - 24dboct	80hz - 24dboct	50hz - 24dboct	70hz - 24dboct	80hz - 24dboct
Input connectors		4 wire cable	4 wire cable	4 wire cable	4 wire cable	4 wire cable
Net dimensions (WxHxD)	mm	615x430x415	430x430x400	430x430x400	285x285x250	168x222x200
	inch	24.41x16.92x16.33	16.92x16.92x15.74	16.92x16.92x15.74	11.22x11.22x9.84	6.61x8.74x7.87
Net weight	kg/lb	38 / 83.7	21 / 46.3	15 / 33	7 / 15.4	3.5 / 7.7
Transport dimensions(WxHxD)	mm	715x530x515	530x530x500	530x530x500	365x365x330	250x300x280
	inch	28.14x20.86x20.27	20.86x20.86x19.68	20.86x20.86x19.68	14.37x14.37x12.99	9.84x11.81x11.02
Transport weight	kg/lb	40 / 88.2	23 / 50.7	17 / 37	9 / 19.8	4.5 / 9.9

# INDOOR PRODUCTS





The innovative design makes the CS series more than just another conference system. With its ECM capsule, intelligent automatic mixing technology and integrated acoustic and mechanical system, the conference system provides turnkey solution with natural, feedback-free audio performance whatever the environment. This conference system is ideal for conferences up to 150 attendees. The system is composed of 1 central unit and up to a maximum of 150 chairman or delegate console.



CS1-CU



CS1-CH

## FBT AC CS 1CU

**Code 27510**

### CONTROL UNIT

- Controls the chairman and delegate microphones as well as the connections to other audio inputs and outputs
- Self-powered

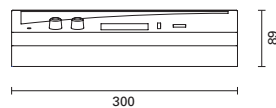

## FBT AC CS 1DU

**Code 27512**

### MICROPHONE CONSOLES

#### Delegate microphone base

Provides the facility for the user to take part in the conference via the gooseneck microphone, a PTT ON/OFF switch is provided as is an internal loudspeaker and an external earphone socket

- Flexible condenser microphone
- Diameter without microphone 170x115x90mm
- Microphone length 400mm
- Net weight 1100g

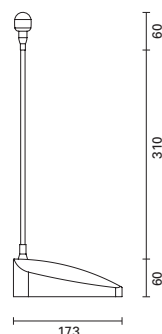

## FBT AC CS 1CH

**Code 27511**

### MICROPHONE CONSOLES

#### Chairman microphone base

It has the same features of the CS DU model, but with the following difference:

- A priority switch allowing the chairman to control the conference by muting temporarily or completely clearing all active delegate microphone units

FBT AC D7P		Cables
Model	Code	Dim.
FBT AC D7P-10	<b>37648</b>	10 mt
FBT AC D7P-20	<b>37649</b>	20 mt
FBT AC D7PDH-1	<b>37650</b>	

# 42 | Conference Systems and intercom systems

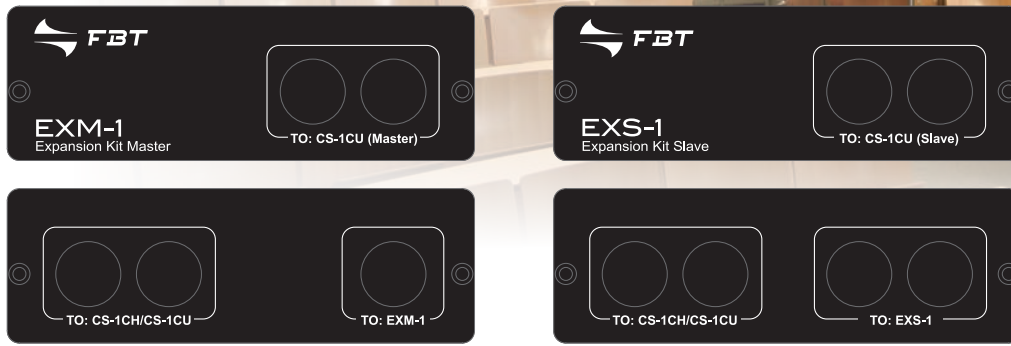

## FBT AC EXM-1

## FBT AC EXS-1

Code 37646

Code 37647

### EXPANSION KIT

FBT AC expansion kit, combined with D7PDM-1 extension cables, can expand the number of using units of conference discussion system from 50 to 150 by adding maximum two additional FBTAC CS-1CU functioning as power supply units only. The system is controlled by the master FBTAC CS-1CU unit. Using D7P-10 or D7P-20 extension cables to extend the operation distance.

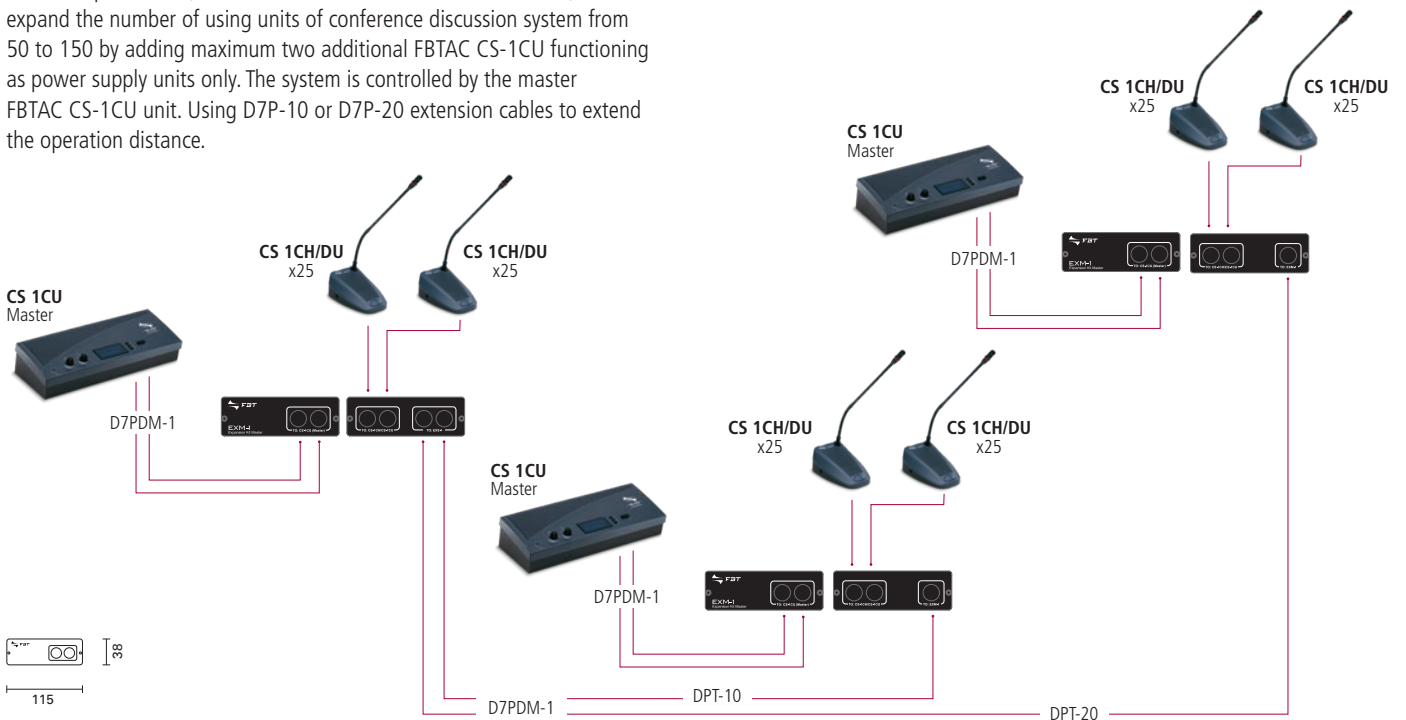



FBT AC CS 1CU	
<b>Code</b>	<b>27510</b>
<b>CONFERENCE SYSTEM CS SERIE</b>	
Voltage	Vac 100 ~ 264, 50/60Hz
DC supply to contribution units	±15V ±1V
<b>Line, Telephone and Insertion-unbalanced</b>	
Input sensitivity	dBV -14/+11 (nominal/maximum)
Input impedance	Kohm 33
Output level	dBV 14/+11 (nominal/maximum)
Output impedance	ohm 500
<b>Tape Recorder-unbalanced</b>	
Input sensitivity	dBV -20/+5 (nominal/maximum)
Input impedance	Kohm 47 (for L & R channel)
Adjustment	dBV -20/+5
Output level	dB +0/-30
Output impedance	ohm 500
<b>External Microphone input-balanced</b>	
Input sensitivity	dBV -56
Adjustment	dBV +6/-6
Power supply Phantom	12V±1V, 2*680ohm (±2%)
<b>Headphone Output</b>	
Output level	dBV -8/+2
Allowed Impedance	ohm 22
<b>Gooseneck Microphone</b>	
Type	Back Electret Condenser
Frequency Response	Hz 50 ÷ 18000
Polar Pattern	Cardioide
Max. SPL for 1% THD	dB 125
Gooseneck Length	mm 400 (15")
Dimensions (WxHxD)	mm 300x89x150
Weight	gr 1745



	FBTAC EXM 1	FBTAC EXS 1
<b>Code</b>	<b>37646</b>	<b>37647</b>
Input	7-pin DIN Connector	7-pin DIN Connector
Output	7-pin DIN Connector	7-pin DIN Connector
Power supply	-	-
Power input	W -	-
External loudspeaker impedance	ohm -	-
Dimensions	mm 115x65x38	115x65x38
Bases dimensions	mm -	-
Flex cable and microphone length	mm -	-
External loudspeaker dimensions	mm -	-



## MD-S 1100

**Code 10040**

### HAND-HELD MICROPHONES DYNAMIC CARDIOID

- ON-OFF switch
- Male XLR connector
- Anthracite grey body
- Black mesh and antipop filter
- High performance
- High-quality voice reproduction
- Low distortion
- High resistance to knocks
- Special cartridge suspension mount to isolate the microphone from handling noise
- **Ideally suited for speech applications**

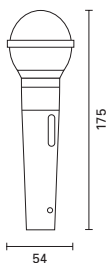

## MD-S 1300

**Code 10042**

### HAND-HELD MICROPHONES DYNAMIC PERCARDIOID

- ON-OFF switch
- Male XLR connector
- Anthracite grey body
- Black mesh and antipop filter
- High performance
- High-quality voice reproduction
- Low distortion
- High resistance to knocks
- Special cartridge suspension mount to isolate the microphone from handling noise
- **Ideally suited for singing applications**

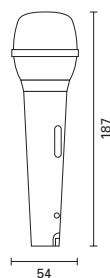



## MC-F 5042

**Code 10044**

### ELECTRET MICROPHONE WITH GOOSENECK

- Male XLR connector
- Low reflectivity black finish
- Outstanding directional characteristics
- Ideal for:
  - auditoriums
  - shopping centres
  - conference halls

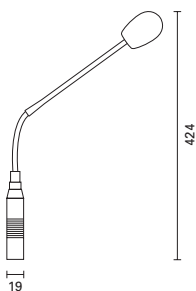

## MD-F 5045 SI

**Code 15294**

### DYNAMIC MICROPHONES CARDIOID WITH GOOSENECK

- Same characteristics as the MD-F 5045 S with push-to-talk switch

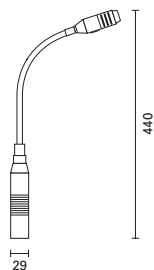

## KMS 400BK

Floor stand



**Code 32882**

Adjustable floor stand

## MSA 100BK

Floor stand



**Code 39321**

Microphone stand with boom arm

## KDT 500BK

Table microphone stand



**Code 32883**

Adjustable table microphone stand

## SU 30

Universal clamp-on



**Code 11586**

Universal hand-help microphone clamp-on



## CM 601

Code 27516

### LOW PROFILE PANORAMIC MICROPHONE, ELECTRET CONDENSER

- On/off switch,
- The switch can be programmed for the push on/off, push/ to talk, push/to mute functions
- LED indicator
- Three-position low cut switch, minimizing mechanical noise
- 3 pin Mini XLR-M output connector
- 36-52 VDC Phantom Power, 88 g net weight
- Specially suitable for conference tables, altars and stage floors

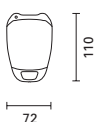

## FBTAC GM 5206 L - 5212 L - 5218 L

Code 27515

Code 27514

Code 27513

### CONDENSER MICROPHONE

- XLR connector

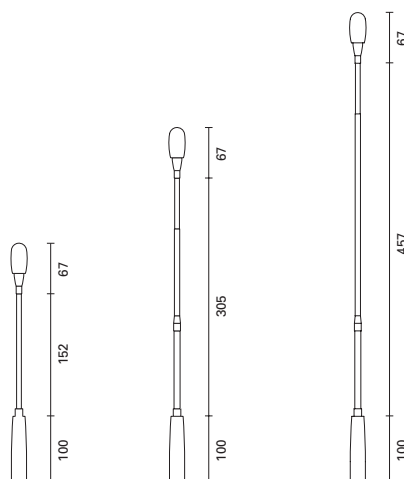



		<b>MD-S 1100</b>	<b>MD-S 1300</b>	<b>MC-F 5042</b>	<b>MD-F 5045 SI</b>
<b>Code</b>		<b>10040</b>	<b>10042</b>	<b>10044</b>	<b>15294</b>
Characteristics		Dynamic	Dynamic	Electret	Dynamic microphone with push-to lock switch
Directivity		Cardioid	Hiper-Cardioid	Cardioid	Cardioid
Frequency Response	kHz	80 ÷ 13	50 ÷ 18	80 ÷ 16	100 ÷ 12
Sensitivity (0dB-1V/micro bar, 1000 Hz)	dB	-75 ± 3	-72 ± 3	-68 ± 3	-77 ± 3
Output impedance	ohm	500	250	250	500
Power Supply		-	-	Phantom 9:52 Vdc	-
Material		Zamak	Zamak		
Accessories included		Stand SU30	Stand SU30	-	-
Microphone cables (optional)		XMF-6 XMF-10 XMF-15 XMF-20 XMF-30	XMF-6 XMF-10 XMF-15 XMF-20 XMF-30	-	-
Dimensions (WxHxD)	mm	ø 54x175	ø 54x187	ø 19x424	ø 29x440
Weight	Kg	2,2	3,59	1,35	3,15



		<b>CM 601</b>	<b>FBTAC GM 5206 L</b>	<b>FBTAC GM 5212 L</b>	<b>FBTAC GM 5218 L</b>
<b>Code</b>		<b>27516</b>	<b>27515</b>	<b>27514</b>	<b>27513</b>
Characteristics		Electrete Condenser	Electrete Condenser	Electrete Condenser	Electrete Condenser
Directivity		Half-Cardioid	Cardioid	Cardioid	Cardioid
Frequency response	kHz	30 ÷ 12	80 ÷ 18	80 ÷ 18	80 ÷ 18
Sensitivity	dB	-53 ± 3	-60	-60	-60
Low Frequency Roll-off	Hz	80, 120	-	-	-
Output impedance	ohm	100	220	220	220
Maximum SPL	db	125 a 1 kHz	125	125	125
Signal to noise ratio	dB	67			
Power supply	Vdc	36 ÷ 52	36 ÷ 52	36 ÷ 52	36 ÷ 52
Power consumption	mA	≤ 6	-	-	-
Switches		Push control: on/off Sunction selection: push on/off, momentary on, momentary off Low cut: low frequency roll-off	-	-	-
Output connector		3P Mini XRL-M type	XRL	XRL	XRL
Dimensions (WxHxD)	mm	72X110	152	305	457
Weight	Kg	0,88			



## FBTAC ST 5050

Code 27499

### UNIVERSAL MICROPHONE BASE

- Both phantom power and 9V battery power supply
- On/off switch with possible push/ to talk, push/to mute

## FBTAC ST 850

Code 27500

### WIRELESS MICROPHONE BASE

It is automatically set to be wired or wireless, adding the transmitter and receiver

- On/off switch
- The base operates with power transmitters and it is compatible with **FBTAC-PT-850B** transmitters - code 38901 page 51
- Where wireless transmitters not available, it will be enough to connect ST850 to a microphone cable with Phantom power supply: it will function as a standard flexible microphone

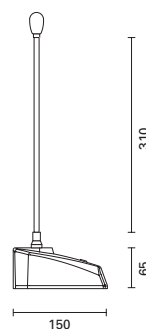
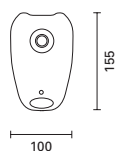





### BF-T 5043 L

**Code 18322**

#### DESK MICROPHONE BASES

Desktop base with ON-OFF switch, gooseneck and cardioid electret condenser microphone

- Complete with a 5-metre cable fitted with a male XLR connector and 2 wires for the activation of the chime priority
- Die-cast zinc base
- Lamp ring
- Touch-switch
- Ideal for all applications, especially for churches and conference halls

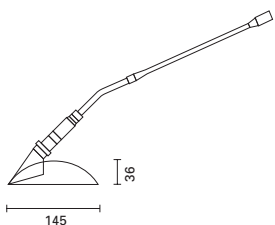

### MB-T 6400 S

**Code 28840**

#### DESK MICROPHONE BASES

Desk base with ON/OFF switch, flexible gooseneck with cardioid dynamic microphone

- 5 metre cable with male XLR connector and 2 conductors for priority activation (ding-dong)

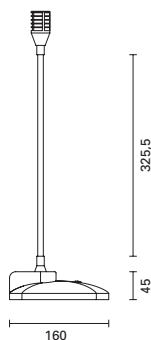

# 50 | Microphones Bases

High sensitivity  
and wide frequency  
response.



## MB-T 8001

## MB-T 8004

## MB-T 8008

### AL 8000 Power Supply



### Code 17074

Power Supply +15/-15V for pre amplified microphone bases of MB-T8000 series

### AL 8000 Multipair Shielded cable

Model	Code	Dimens.
STH 02-022	<b>13360</b>	2x2x0,22
STH 05-022	<b>13103</b>	5x2x0,22
STH 09-022	<b>13104</b>	9x2x0,22

Code 19543

Code 11828

Code 12122

### DESKTOP BASES

The microphone bases in the MB-T 8000 series feature a plastic body with a metal base. These products stand out for their high sensitivity and wide frequency response and the microphones feature a cardioid polar curve. The bases are equipped with a functional 3-position switch, ON push-to-lock, OFF and push-to talk ON as well as an emergency button.

- Pre-amplified (output 0dBu)
- Dynamics compressor to ensure optimal level of clarity
- Internal message generator to indicate the start and end of microphone messages and for an emergency signal
- Option to control priority (music off)
- Management of 4 or 8 zones independently, depending on the model, and general calls
- For the management of a larger number of zones, upon request

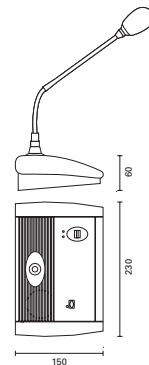

**MB-T 8001**  
1 zone

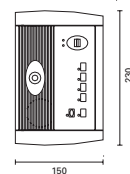

**MB-T 8004**  
4 zone

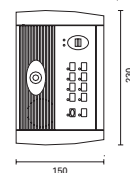

**MB-T 8008**  
8 zone

## ABS structure with electret microphone and stem with a flexible section at the bottom.

Equipped with one hold-down (PTT) call key, one toggle (LOCK) call key for long messages and a LED signaling activation of the microphone. The bases can be mixed with one another or interlocked with two priority levels. The level of the microphone signal and that of the alerting signal (chime generator included) are adjustable from the rear.



### MBT 1101

### MBT 1106

### MBT 1112

### MBT 1112E

Code 37739

Code 37492

Code 37493

Code 37494

CV 2010 Cable

Code 35541

#### PRE-AMPLIFIED BROADCASTING PAGING UNITS

MBT 1101 microphone stations can be used simply and rapidly with the amplifiers of the MPA 5000, MXA 1000, MXA 3000 and MDS 6000 range. It is essential to use CAT5e SF/UTP shielded cables (IN input UNITS), and it is possible to connect up to 6 microphone stations in cascade fashion. The output level can be adjusted by means of the appropriate rear-panel control (LEV). Standard paging units can be used in the Voice Evacuation Systems. The units are connected to one another in cascade formation, and the connecting cables (CAT5e SF/UTP) carry both the analogue audio signal and the digital signal for the controls and station addresses. **MBT 1106** call station can make selective calls to up to a maximum number of 6 zones and the **MBT 1112** up to 12.

The **MBT 1106E** extension module enables 12 programmable shortcut keys for one or more functions to be added. It is possible to connect up to two expansion modules to the MBT 1112.

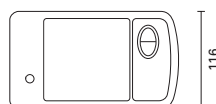
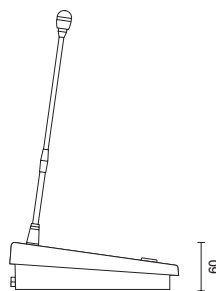

**MBT 1101**  
1 zona

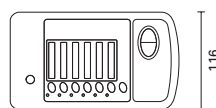

**MBT 1106**  
6 zone

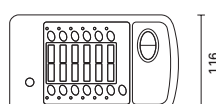

**MBT 1112**  
12 zone

200

# Microphones Bases



		<b>FBTAC ST 5050</b>	<b>FBTAC ST 850</b>	<b>BF-T 5043 L</b>	<b>MB-T 6400 S</b>
<b>Code</b>		<b>27499</b>	<b>27500</b>	<b>18322</b>	<b>10044</b>
Characteristics		Microphone bases	Back Electret Condenser	Electrete	Dynamic
Frequency response	kHz	20 ÷ 20	50 ÷ 18	70 ÷ 18	100 ÷ 18
Directivity		-	Supercardioid	Cardioid	Cardioid
Sensitivity	dB	-	-	-59+/- 3	-75 ± 3
Output impedance	ohm	-	Wireless 2kΩ Wired 100Ω	250	500
Power supply	Vdc	Phantom power 12-48V or battery power 9V	Wireless 5 - Wired 12 - 48 Phantom power	Phantom 12 ÷ 48	-
Power consumption	mA	2,07 (BAL) - 1,34 (UNBAL)	Wireless ≤0.5 - Wired ≤05.5	-	-
Switches		Microphone selection: ECM MIC unbalanced input, ECM MIC balanced input, Dynamic MIC input	Push control on/off	Push control on/off	Push control on/off
Connectors		Unbalanced and balanced audio input (XRL 3P Female) Unbalanced and balanced audio output (XRL 3P Male)	Wireless 4P <mini XRL Wired 3P XRL (M)	XLR 3P male (5m cable included)	XLR 3P male (5m cable included)
Sensitivity	db	-	Wireless -66±3 (1.58mV) 0 = 1V/ bar - Wired -56±3 (1.58mV) 0=1V/μ bar	-59 -/+3	-59 -/+3
Dimensions (WxHxD)	mm	100x155	100x65x150	145x100x36	160x98x45
Weight	Kg	0,82	1	0,786	1,75



		<b>MB-T 8001</b>	<b>MB-T 8004</b>	<b>MB-T 8008</b>
<b>Code</b>		<b>19543</b>	<b>11828</b>	<b>12122</b>
Features		Base with switch, emergency button	Base with switch, 4-zone selection emergency button	Base with switch, 8-zone selection emergency button
Microphone		Electret	Electret	Electret
Frequency response	kHz	70 ÷ 18	70 ÷ 18	70 ÷ 18
Directivity		Cardioid	Cardioid	Cardioid
sensitivity	dB	-63 ± 3	-63 ± 3	-63 ± 3
Output impedance	ohm	600	600	600
Power supply	Vdc/mA	±15 /80	±15 /80	±15 /80
Warning/emergency signals		CHIME: 2 Tones CHIME: 4 Tones Emergency	CHIME: 2 Tones CHIME: 4 Tones Emergency	CHIME: 2 Tones CHIME: 4 Tones Emergency
Output voltage	dBu	0 (0,775Vrms) balanced	0 (0,775Vrms) balanced	0 (0,775Vrms) balanced
N° of selectable zones		-	4	8
Material		Plastic with steel base	Plastic with steel base	Plastic with steel base
Accessories included		Antipop filter	Antipop filter	Antipop filter
Optional accessories		Multipair Shielded cable 5x2x0.22 <b>STH05-022</b>	Multipair Shielded cable 5x2x0.22 <b>STH05-022</b>	Multipair Shielded cable 5x2x0.22 <b>STH09-022</b>
Dimensions (WxHxD)	mm	ø 9x370	ø 9x370	ø 9x370



		<b>MBT 1101</b>	<b>MBT 1106</b>	<b>MBT 1112</b>	<b>MBT 1112 E</b>
<b>Code</b>		<b>37739</b>	<b>37492</b>	<b>37493</b>	<b>37494</b>
Type		Electret	Electret	Electret	-
N° of selectable zones		-	6	12	12
Power supply	kHz	12 Vcc / 24 Vcc	18 Vcc / 36 Vcc	18 Vcc / 36 Vcc	-
Absorption @ 12 Vdc	mA	40	-	-	-
Absorption @ 24 Vdc	mA	50	16	22	20
Frequency response		100 ÷ 15.000 Hz	100 ÷ 14.000 Hz	100 ÷ 14.000 Hz	-
Speech filter @100 Hz	dB	-	-10	-10	-
Audio output level		-	2,2 Vmax	2,2 Vmax	-
Audio level adjustable		1,2 Vrms (Balanced)	-	-	-
Warning signal level (chime) adjustable		0,8 Vpp	-	-	-
Dynamic limiter		yes	yes	yes	-
Dimensions	mm	116x60x200	116x60x200	116x60x200	116x60x200
Weight	Kg	0,82	0,58 Kg	0,60 Kg	0,50 Kg

## LM - 10

### Lavalier microphones



## Code 13544

Lavalier microphones have electrical and mechanical characteristics to guarantee reproduction of clear and intelligible speech for the entire system. The compact dimensions and weight ensure use in all cases where the utmost freedom of movement is indispensable.

## HM - 26

### Handset microphones



## Code 13543

Headset microphones have electrical and mechanical characteristics to guarantee reproduction of clear and intelligible speech for the entire system. The compact dimensions and weight ensure use in all cases where the utmost freedom of movement is indispensable.

## AVL 606

### Microphone



## Code 14142

As well as the characteristics of the other two models, this microphone features special sweatproof protection to enable use in all applications subject to high levels of humidity or perspiration. (Typical applications include gymnasiums, swimming pools, camp sites etc.)



## WM 505/...

- Code 40445+40450** 175 Mhz
- Code 18472+40449** 214 Mhz
- Code 18476+40448** 204 Mhz
- Code 40447+40452** 203.25 Mhz
- Code 31250** 203.30 Mhz
- Code 40446+40451** 216 Mhz

### WIRELESS MICROPHONES

Design philosophy and technology aimed at guaranteeing optimal quality and reliability with high level performance. Receiver with SWITCHING DIVERSITY technology, to ensure signal selection at all times at the radio frequency with the best intensity, thereby ensuring top quality and reproduction stability in sound amplification systems.

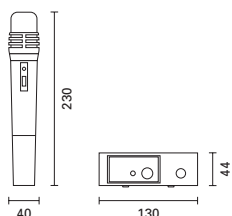

## WM 705 A/L

- Code 14827** 181 Mhz
- Code 14828** 203 Mhz
- Code 14830** 207 Mhz

### WIRELESS MICROPHONES

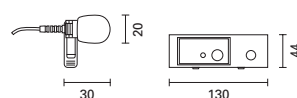



## **FBTAC US 8001D**

**Code 38640**

### **UHF PLL TRUE DIVERSITY RECEIVER**

- Suitable for 1 transmitter (FBTAC Mh 750, FBTAC Mh 920, FBTAC PT 850 B)
- Preset with 16 selectable UHF channels (720-744MHz)
- Diversity technology preventing from signal losses in RF links
- Noise Mute e and pilot tone squelch circuit to avoid interferences
- Balanced and unbalanced XLR outputs
- 1/2 U rack metal chassis

## **FBTAC Mh 750**

**Code 38376**

### **MICROPHONE WITH UHF PLL TRANSMITTER**

- 16 selectable channels
- Frequency band: 720-744MHz
- Advanced circuits guaranteeing stable transmission signals
- Squelch tone-key
- Wide dynamic range and flat frequency response
- Internal antenna, lightweight hard plastic case



## FBTAC PT 850B

Body pack transmitter



### Code 38901

- 16 selectable channels
- Frequency band: 720-744MHz
- AA battery supply
- Featuring 4P mini XLR connector
- Hard and solid plastic case
- Compatible with lavalier and boom microphones
- LED display, designed for waist carrying

## FBTAC CM 501

Lavalier microphone



### Code 27497

Lavalier unidirectional cardioid condenser microphone 4P mini XLR connection, frequency response 100-15,000Hz; Sensitivity (at 1,000Hz):  $-60 \pm 3$  dB\* (1mV)\*0dB=1V/ $\mu$ bar, 1kz; Impedance 2.2Kohm; wide dynamic range and excellent frequency response; small size for low visibility; including the clip for easy hanging on ties, suits, lapels. Net weight: 21.5 gr.

## FBTA CX 504

Cardioid microphone



### Code 27498

Cardioid condenser boom microphone; perfect for voice. 4P mini XLR connection, frequency response 30-18,000Hz; Sensitivity (at 1,000Hz):  $-68 \pm 3$  dB\*(0.4mV)\*0dB=1V/ $\mu$ bar, 1kz; impedance 680Kohm; excellent pre-feedback gain and noise insulation; light weight enabling free movement; ergonomic design guaranteeing wearing comfort; Net weight: 56.3 gr.

## FBTAC US 902D

### Code 38375

#### UHF PLL TRUE DIVERSITY RECEIVER

- Preset with 16 selectable UHF channels (720-744MHz)
- Suitable for 2 transmitters (FBTAC Mh 750, FBTAC Mh 920, FBTAC PT 850 B)
- Diversity technology preventing from signal losses in RF links
- Noise Mute e and pilot tone squelch circuit to avoid interferences
- LCD Display
- Balanced and unbalanced outputs
- 1 U rack metal chassis

## FBTAC Mh 920

### Code 38884

#### MICROPHONE WITH UHF PLL TRANSMITTER

- 16 selectable channels
- Frequency band: 720-744MHz
- Advanced circuits guaranteeing stable transmission signals
- Wide dynamic range and flat frequency response
- Advanced circuits and squelch key avoiding interferences
- Internal antenna
- Suitable for condenser or dynamic cartridge
- LOCK-ON function to avoid accidental interruptions

# Wireless Microphones



		WM 505/...					WM 705 A/L	
Code		11575	11574	14922	14923	14924	14827	14828
	Mhz	175	214	204	212	203	181	203
Transmitter type		Hand-held	Hand-held	Hand-held	Hand-held	Hand-held	Lavalier and Headset	Lavalier and Headset
Audio band		50 Hz - 15 KHz	50 Hz - 15 KHz	50 Hz - 15 KHz	50 Hz - 15 KHz	50 Hz - 15 KHz	50 Hz - 15 KHz	50 Hz - 15 KHz
Microphone type		Dynamic	Dynamic	Dynamic	Dynamic	Dynamic	Electret	Electret
Directivity		Cardioid	Cardioid	Cardioid	Cardioid	Cardioid	Cardioid	Cardioid
Power RF	mW	10	10	10	10	10	5	5
Power supply	V	1,5	1,5	1,5	1,5	1,5	3	3
Absorption	mA	60	60	60	60	60	25	25
Duration		Tipico 12 ore	Tipico 12 ore	Tipico 12 ore	Tipico 12 ore	Tipico 12 ore	Tipico 12 ore	Tipico 12 ore
Operation		SW Diversity Quartz-controlled	SW Diversity Quartz-controlled	SW Diversity Quartz-controlled	SW Diversity Quartz-controlled	SW Diversity Quartz-controlled	SW Quartz-controlled	SW Quartz-controlled
Antenna		2	2	2	2	2	2	2
Power supply		12/18 V external	12/18 V external	12/18 V external	12/18 V external	12/18 V external	12 V dc/300 mA with power supplier	12 V dc/300 mA with power supplier
Squelch		Adjustable	Adjustable	Adjustable	Adjustable	Adjustable	Adjustable	Adjustable
Audio Output		0:300 mV	0:300 mV	0:300 mV	0:300 mV	0:300 mV	12 V dc/300 mA 0:300 mV	12 V dc/300 mA 0:300 mV
Weight	Kg	0,9	0,9	0,9	0,9	0,9	0,9	0,9



		FBTAC US 8001D	FBTAC Mh 750	FBTAC US 902D	FBTAC Mh 920
Code		38640	38376	38375	38884
Oscillation type		PLL	-	PLL	-
Channel		16	-	16	-
Frequency response	Mhz	720 - 744	-	720 - 744	-
Deviazione in frequenza	Khz	-	+/- 48	-	+/- 48
Bandwidht	Mhz	24	-	24	-
Operation range	m	100	-	100	-
Receiver mode		Diversity	-	Diversity	-
Signal/Noise ratio	dB	> 100	> 100 (1kHz - A)	> 100	> 100 (1kHz - A)
Current consumption	mA	-	100	-	100
Sensitivity RF	dBm	-107 (12db S/N AD)	-	-107 (12db S/N AD)	-
Display		LED	-	LCD	-
LCD / LED indicators Power		-	On/Off Power Battery Level	-	On/Off Power Battery Level
Batteries		-	2AA 1,5V	-	2AA 1,5V
Controls		On/Off, volume, channel Up/Down	-	On/Off, volume, channel Up/Down, Squelch level	-
Audio Output Level	dB	-12	-	-12	-
AF Output Impedance		600 ohm unbalanced	-	2,2 Kohm unbalanced	-
Squelch		Pilot tone and Noise Mute	-	Pilot tone and Noise Mute	-
Operating voltage		12-18VDC, 600mA	-	12-18VDC, 600mA	-
Outputs		1 balanced XLR and 1 unbalanced Jack 6,3mm	-	2 balanced XLR and 1 unbalanced Jack 6,3mm	-
Dimensions (WxHxD)	mm	221x40x152		480x45x232	





## FBT AC MX-8

**Code 37645**

### AUTOMATIC MICROPHONE MIXER

The microphone automatic mixers provide great convenience to sound reinforcement installation with any size and any combination. Full feature design includes

- Daisy-chain with unlimited number of the mixer
- Three operation modes: one-channel-at-a-time, all active or override
- Switchable output levels between mic. and line level
- Individual gain control and phantom power for each channel
- Last in stays on for continuous ambience sound
- Control voltage provided to trigger external device such as a speaker switching and camera switching

The outstanding performance enables effective managing of multi-microphone installation including corporate boardrooms, conference rooms, government builds, houses of wokship, classrooms

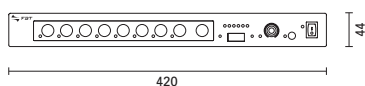

FBT AC MX-8	
<b>Code</b>	<b>37645</b>
Type	XLR
Mic	Kohm 4.7
Line	Kohm 20
<b>OUTPUT</b>	
Type	XLR
Mic	ohm 300
Line	ohm 200
MAX output level	dB >17
MAX gain	dB >70
Frequency response	Hz 35~20,000
THD%	<0.06%
Signal-to-noise radio	dB >70
Input attenuation	dB -50
Phantom power	V +48
Mic In attenuation	dB -10 / -20
Mic attenuation	dB -10 / -15 / -20
Output attenuation	dB -50
Voltage output	+4VDC ±0.3V
Power supply	18VDC, 1A
Power consupion	W 13.5
Fuse	T0.5AE 250V (Slow-Blow)
Dimensions (WxHxD)	mm 420x44x198,5
Peso netto	Kg 2.25

### D8P - 1

Extension cable

### Code 37936

- Din 8 Pin Male/Male Cable
- Lenght 0,8 m



## M 12X4

Code 18147

### PREAMPLIFIER/MIXER WITH 12 INPUTS AND 4 OUTPUTS

- 4 micro/line inputs
- Priority of the 4 microphone inputs over all other inputs and priority of the first input over the other 3
- Volume control and voice control for the 4 microphone inputs
- Phantom 24V. 4 stereo line inputs on double RCA with selection via purpose-provided selector knob
- General volume and tone control
- 2 XLR outputs for
- Left and right channel with independent volume control for each channel
- One stereo output and one stereo recording output
- 1 rack unit

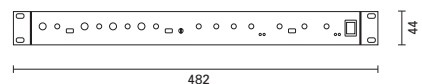
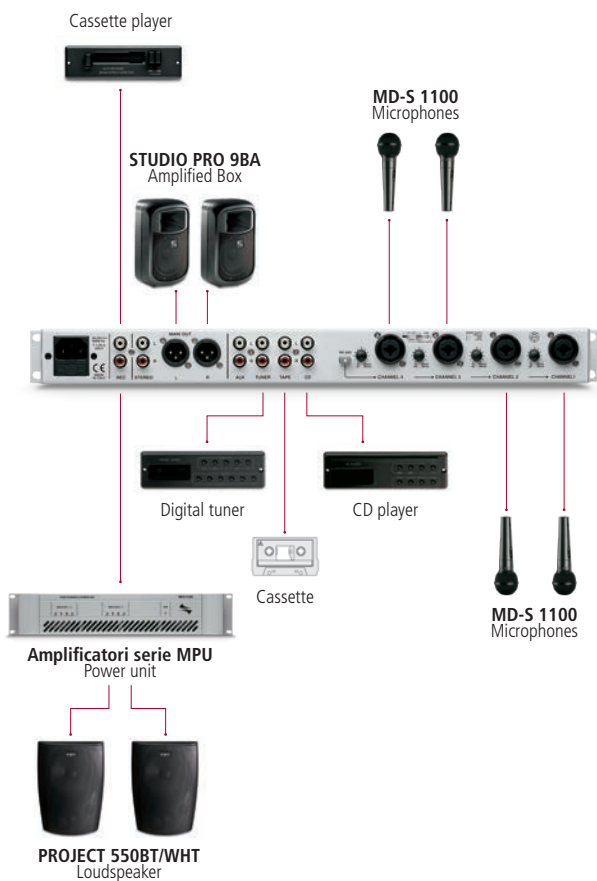

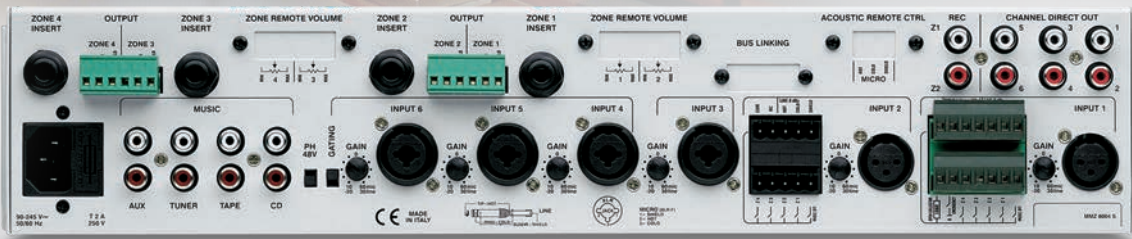

## MMZ 8004 S

Code 19812

### PREAMPLIFIER/MIXER WITH 10 INPUTS AND 4 OUTPUTS

- 6 Combo inputs
- 4 stereo line inputs for CD, Tape, Tuner and Aux, selected on each output zone
- 4 output buses with independent control
- Microswitch on each input for routing to each output
- Adjustable sensitivity of micro and line inputs
- Designed for connection to up to 2 amplified microphone bases from the MBT8000 series equipped with zone selector switches
- Designed for connection to emergency detection systems for guided evacuation, with priority over all inputs
- Automixer operating mode on 3 microphone channels, thanks to the GATING function (this function allows for the level of speech to be increased before the "Larsen effect" - feedback whistling - occurs)
- Internal switching power supply from 100V to 230V and from 50Hz to 60Hz
- 2 rack units

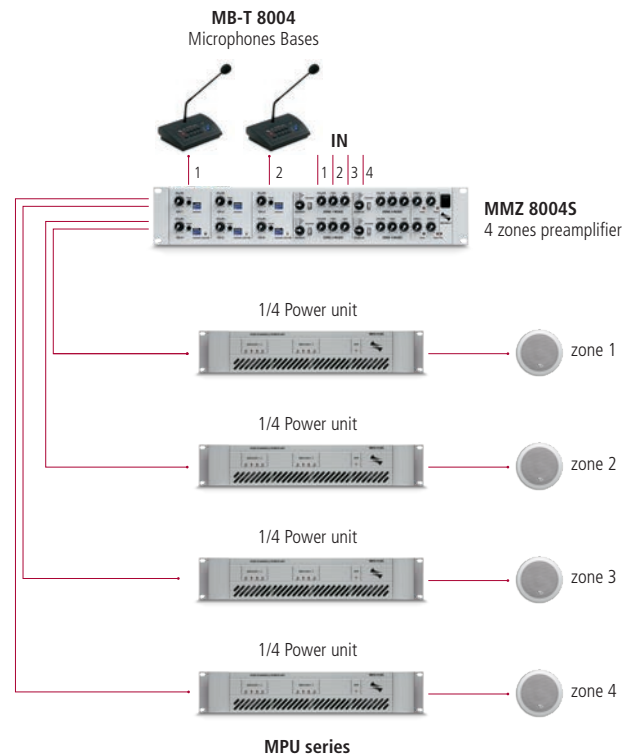
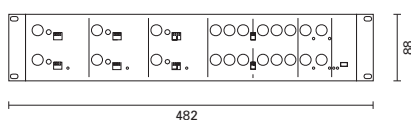

# Selective voice/music switching in 8 audio zones

The **MZU 2008** switching unit can be installed in 19" racks for selective voice/music switching in 8 audio zones, with the possibility to increase the number of zones as multiple of 8, adding other MZU 2008 in cascade. Selection of the zones in which the music is to be interrupted and an announcement transmitted is carried out from the MBT 8008 control console.

Using the 8 "MUSIC" keys on the front panel, you can choose in which of the 8 audio zones to play the normal background music and in which zones no music is to be played.

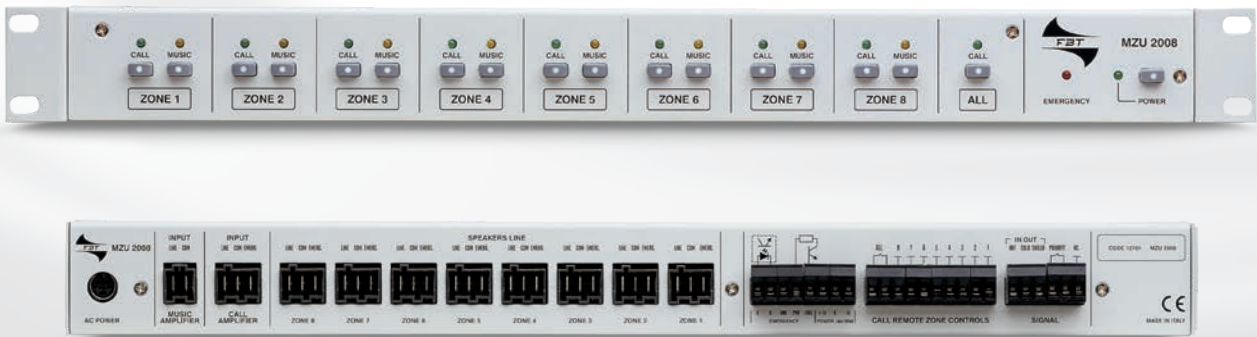

## MZU 2008

Code 12944

### ZONE PAGING UNIT

The system can be configured in one of the following ways:

- the 2 inputs of the unit are driven by two amplifiers, one of which is dedicated to voice transmission and the other to music transmission. The 8 outputs of the unit drive the 8 speakers of the 8 audio zones.
- The 2 inputs of the unit are driven by two signal preamplifiers, one of which is dedicated to voice transmission and the other to music transmission. The 8 outputs of the unit drive the 8 power amplifiers dedicated to sound diffusion in the 8 audio zones.

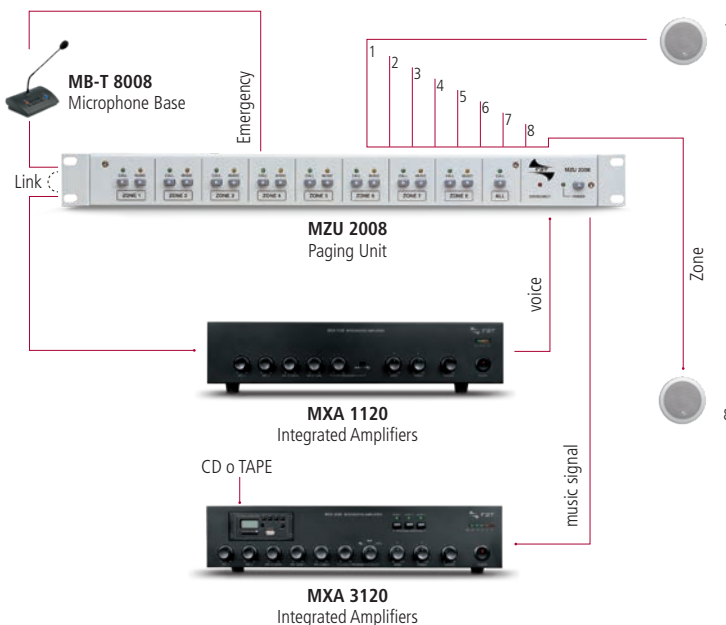

The **DMM 8008** is a high performance 8 input x 8 output **digital matrix mixer**; Specially designed for commercial and professional application such as Conference rooms, Auditoriums, Sport utility buildings, House of worship, Pubs and Disco. It includes 8 independently switchable Line/Mic inputs with Phantom power supply, 8 Line outputs, managed by a powerful 48kHz 24 Bit DSP engine, in addition to high performance 24 Bit AD/DA converters. The **DMM 8008** supports a full matrix mixing mode where inputs may be routed/mixed in any ratio to any output. Each Mic/Line input channel provides Lo/Hi pass 1st order filters, 3-band parametric EQ, Noise Gate function and Gain control. In addition Mic inputs include a Feedback Eliminator function, based on a powerful

«Pitch Shifting» algorithm, particularly suitable for voice applications. Automixing function automatically adjusts input level to make operating easier using either NOM (Number of Open Mics) attenuation function or Gain sharing algorithm. In addition Ducking process enforces a «priority order» of open microphones in order that high-priority inputs attenuate lower-priority inputs. Each output offers up to 5-band of parametric equalization, crossover filters, RMS compressor, Peak limiter, Phase and Delay controls; 8 digital In/Out ports are provided for general purpose (preset recall, trigger third parts or device); 8 front knobs provides a quickly way to control input Gain; Up to 32 units can be managed by software applications.



## DMM 8008

Code 38885

### DIGITAL MATRIX 8X8

- Excellent audio performance with 24 bit converters coupled with 48kHz sample rate
- 8 Mic/Line inputs, 8 outputs with full matrix mixing, 3 band parametric equalization and Low/High pass filters per input channel
- 5 band parametric equalization per output channel; each band can be switched to peaking, Low/High shelving with variable Q response
- Crossover filters with slopes from 6dB/Octave up to 24dB/Octave including Butterworth, Bessel, Linkwitz-Riley
- Gain control, Noise Gate, Feedback eliminator (Mic input only) per input channel
- Each output features a precision dynamic range controller composed of a Peak Limiter and a RMS Compressor with selectable ratio and variable knee
- Automixing functions include: Configurable NOM attenuation, Gain sharing algorithm, Priority Ducking
- Adjustable Delay time up to 380mS per output channel
- Front panel interactive LCD display for local access and configuration
- Front panel 6-led status indicators per In/Out channel
- 8 front knobs available for Mic input Gain control
- 4 input contacts for additional 4 preset selections with priority configuration
- 4 digital output ports for triggering external devices
- Simultaneous control up to 32 units via PC software
- Security lockout
- TCP/IP, RS 485 and USB connection for remote controls

### 2 AVAILABLE MODE TO MANAGE THE DMM 8008



Via **RS 485 / TCP-IP / USB** - PC software for system design and real time control.



Via **RS 485** - Optional Wall Control Panel **WP 8008** configurable for global or single zone control.

### WP 8008

Wall pannel control  
Code 38929



		M 12x4	
Code	18147		
<b>Mono Channels micro</b>	Impedance	kohm	2,2
	Max input signal	dBu	0
	Max gain (@ main Out)	dB	65
	Equivalent input noise (EIN) (between 22Hz and 22KHz unweighted)		- 118
	CMRR (@main out, Gain 75dB)	dB	- 65
<b>Mono Channels line</b>	Impedance	kohm	33
	Max input signal	dBu	30
	Max gain (@main Out)	dB	25
<b>Mono Channels tone</b>	Voice	dB	± 12
<b>Stereo Channels</b>	Impedance	kohm	22
	Max input signal	dBu	10
	Max gain (@ main Out)	dB	10
<b>Stereo Channels tone</b>	High Shelving (@12kHz)	dB	± 15
	Low Shelving (@80kHz)	dB	± 15
<b>General outputs</b>	Impedance	kohm	600
	Distortion + noise@16dBu (main out, 40dB gain)		0,025%
	Signal/noise ratio 20dB		96
	Frequency response (@0/1dB)		20Hz-20kHz
<b>Power supply</b>	100V±230V - 50Hz±60Hz with internal power supply unit		



		MMZ 8004 S	
Code	19812		
Features	Dimensions 2 racks with framewith RAL 7035 grey paint finish		
Microphone-Max gain line	6 micro/line inputs with Combo connector (XLR and JACK) 75dB/2kohm		
Input 1 and 2	Terminal board with option to select output 1,2,3 and 4 from a remote microphone		
Max. gain line/Imp.	4 stereo inputs pin jack RCA 40dB/33kohm		
Frequency response@0/-1dB	20Hz±80KHz		
S/N ratio@20db of gain	dB	110	
Level control	8 Volume controls, 6 GAIN controls, 2 Master		
High pass filter	Channels 1:6 micro/line@80Hz-12dB/oct.		
Voice control	6 adjustment trimmers for voice presence on mic. inputs		
Tone control	2 separate bass and treble tone controls on music inputs only		
Phantom Power supply	48 VDC activated on micro inputs only		
Output 1, 2, 3 and 4	Selectors enable routing of each input to output 1,2,3, 4		
Inputs Music	4 stereo inputs on double RCA for CD, Tape, Tuner and Aux selected on each output zone		
Outputs dB/Impedance	28 dBu/600 ohm balanced		
Auxiliary outputs	Direct outputs channels 1-6 + recording socket output 1,2,3 and 4 0 dBu/600 ohm		
Priority on music	Direct outputs channels 1-6 + recording socket output 1,2,3 and 4 0 dBu/600 ohm		
Remote controls	Optional cards for: remote volume for outputs 1,2,3 and 4 Automatic level control according to background noise on output 1		
Emergency control	Input with photo coupler, Open Collector output		
Insert bus 1 e 2	6.3mm stereo jack socket to connect auxiliary equipment		
Luminous indicators	Led indicating saturation level (peak) on outputs 1,2,3, and 4 - phantom on (48 VDC micro)		
Power supply VAC	230 VAC or 120 VAC with internal power supply unit		
Optional accessories	<b>MMZ-AR</b> card for automatic level control according to background noise (output 1 only) <b>MMZ-VRC</b> card for remote volume control for pair of outputs 1/2		



MZU 2008	
<b>Code</b>	<b>12944</b>
Characteristics	1 rack unit with frame with RAL 7035 light grey paint finish
Inputs	2 music inputs with two wires, speech with three wires, one of which is used for Emergencies (for amplifiers)
Outputs for loudsp. line (zones)	8 with three wires, one of which is used for Emergencies
Max. applicable power	1200Watt/100V, 840Watt/70V, 600Watt/50V, 300Watt/25V
Controls	Speech key for each zone. Music key for each zone. General call key. Power ON-OFF key
Remote controls	Zone selection control. General call command. Activation of emergency and OPEN COLLECTOR output
Output power supply	Vdc +15/0/-15
Luminous indicators	Speech Led and Music Led per zone. General call indicator led. Emergency indicator led. Power ON-OFF indicator led
AC Power supply	230 VAC with external power supply unit - 120 VAC with external power supply unit
Optional accessories	MBT 8008 microphone base



DMM 8008																									
<b>Code</b>	<b>38885</b>																								
<b>AUDIO</b>	<table border="1"> <tr> <td>Analog Output</td> <td>8 electronically balanced (Mic - Line - Unbalanced)</td> </tr> <tr> <td>Uscite Analogiche</td> <td>8 electronically balanced</td> </tr> <tr> <td>Maximum Input Level</td> <td>Line: +14dBu; Mic: -20/0dBu (+6dBu unbalanced)</td> </tr> <tr> <td>Mic Input Gain</td> <td>dB 34dB (22dB analog, 12dB digital)</td> </tr> <tr> <td>Maximum Output Level</td> <td>dBu +14dBu</td> </tr> <tr> <td>THD+N</td> <td>0.005% at 1kHz 0dBu</td> </tr> <tr> <td>S/N</td> <td>dBA &gt;104dBA</td> </tr> <tr> <td>Frequency Response</td> <td>20Hz-20kHz +/-1dB</td> </tr> <tr> <td>AD &amp; DA Converters</td> <td>4 x AK5385B 24bit, 1 x Ak4358 24bit (48kHz)</td> </tr> <tr> <td>Phantom Power</td> <td>Vdc 48Vdc</td> </tr> </table>	Analog Output	8 electronically balanced (Mic - Line - Unbalanced)	Uscite Analogiche	8 electronically balanced	Maximum Input Level	Line: +14dBu; Mic: -20/0dBu (+6dBu unbalanced)	Mic Input Gain	dB 34dB (22dB analog, 12dB digital)	Maximum Output Level	dBu +14dBu	THD+N	0.005% at 1kHz 0dBu	S/N	dBA >104dBA	Frequency Response	20Hz-20kHz +/-1dB	AD & DA Converters	4 x AK5385B 24bit, 1 x Ak4358 24bit (48kHz)	Phantom Power	Vdc 48Vdc				
Analog Output	8 electronically balanced (Mic - Line - Unbalanced)																								
Uscite Analogiche	8 electronically balanced																								
Maximum Input Level	Line: +14dBu; Mic: -20/0dBu (+6dBu unbalanced)																								
Mic Input Gain	dB 34dB (22dB analog, 12dB digital)																								
Maximum Output Level	dBu +14dBu																								
THD+N	0.005% at 1kHz 0dBu																								
S/N	dBA >104dBA																								
Frequency Response	20Hz-20kHz +/-1dB																								
AD & DA Converters	4 x AK5385B 24bit, 1 x Ak4358 24bit (48kHz)																								
Phantom Power	Vdc 48Vdc																								
<b>DSP &amp; PROCESSING</b>	<table border="1"> <tr> <td>DSP Engine</td> <td>Dream SAM3716, 24bit (data) x 96bit (coeff.)</td> </tr> <tr> <td>DSP Resolution</td> <td>24 x 32 bit for filtering process; 96bits resolution on intermediate computation results</td> </tr> <tr> <td>Input Equalization</td> <td>3-band parametric selected as peaking or Low/High shelving with variable Q per input channel Low/High pass 1st order filter per input channel</td> </tr> <tr> <td>Output Equalization</td> <td>5-band parametric EQ selected as peaking or Low/High shelving with variable Q per output channel</td> </tr> <tr> <td>Filter Gain</td> <td>dBu From -12dBu up to +12dBu by 0.5dBu resolution steps</td> </tr> <tr> <td>Center Frequency</td> <td>Selectable with a 1/24th of octave resolution step from 20Hz up to 20kHz</td> </tr> <tr> <td>Filter Q/BW</td> <td>Q from 0.4 up to 10 by 0.1 resolution steps</td> </tr> <tr> <td>Crossover Section HPF/LPF</td> <td>Butterworth 6/12/18/24dB per octave - Bussel, Linkwitz-Riley and custom 12/24dB per octave Filter resolution 1/24th of octave</td> </tr> <tr> <td>RMS Compressor and Peak Limiter</td> <td>Threshold from 14dBu up to -34dBu - Attack time from 5ms up to 200ms (1ms resolution up to 20ms, 10ms resolution up to 100ms and 20ms resolution up to 200ms) - Release time from 0.1 sec up to 3 sec (0.1 sec resolution) - Ratio from 1:1 to 32:1 (compressor only) - Adjustable soft or hard knee (compressor only)</td> </tr> <tr> <td>Delay</td> <td>380,998 ms 21 us increment/decrement steps per output channel only</td> </tr> <tr> <td>Feedback Eliminator</td> <td>Pitch shifting algorithm only for Mic input channels</td> </tr> <tr> <td>Automixing Functions</td> <td>NOM attenuation, Gain sharing algorithm and priority ducking processing</td> </tr> </table>	DSP Engine	Dream SAM3716, 24bit (data) x 96bit (coeff.)	DSP Resolution	24 x 32 bit for filtering process; 96bits resolution on intermediate computation results	Input Equalization	3-band parametric selected as peaking or Low/High shelving with variable Q per input channel Low/High pass 1st order filter per input channel	Output Equalization	5-band parametric EQ selected as peaking or Low/High shelving with variable Q per output channel	Filter Gain	dBu From -12dBu up to +12dBu by 0.5dBu resolution steps	Center Frequency	Selectable with a 1/24th of octave resolution step from 20Hz up to 20kHz	Filter Q/BW	Q from 0.4 up to 10 by 0.1 resolution steps	Crossover Section HPF/LPF	Butterworth 6/12/18/24dB per octave - Bussel, Linkwitz-Riley and custom 12/24dB per octave Filter resolution 1/24th of octave	RMS Compressor and Peak Limiter	Threshold from 14dBu up to -34dBu - Attack time from 5ms up to 200ms (1ms resolution up to 20ms, 10ms resolution up to 100ms and 20ms resolution up to 200ms) - Release time from 0.1 sec up to 3 sec (0.1 sec resolution) - Ratio from 1:1 to 32:1 (compressor only) - Adjustable soft or hard knee (compressor only)	Delay	380,998 ms 21 us increment/decrement steps per output channel only	Feedback Eliminator	Pitch shifting algorithm only for Mic input channels	Automixing Functions	NOM attenuation, Gain sharing algorithm and priority ducking processing
DSP Engine	Dream SAM3716, 24bit (data) x 96bit (coeff.)																								
DSP Resolution	24 x 32 bit for filtering process; 96bits resolution on intermediate computation results																								
Input Equalization	3-band parametric selected as peaking or Low/High shelving with variable Q per input channel Low/High pass 1st order filter per input channel																								
Output Equalization	5-band parametric EQ selected as peaking or Low/High shelving with variable Q per output channel																								
Filter Gain	dBu From -12dBu up to +12dBu by 0.5dBu resolution steps																								
Center Frequency	Selectable with a 1/24th of octave resolution step from 20Hz up to 20kHz																								
Filter Q/BW	Q from 0.4 up to 10 by 0.1 resolution steps																								
Crossover Section HPF/LPF	Butterworth 6/12/18/24dB per octave - Bussel, Linkwitz-Riley and custom 12/24dB per octave Filter resolution 1/24th of octave																								
RMS Compressor and Peak Limiter	Threshold from 14dBu up to -34dBu - Attack time from 5ms up to 200ms (1ms resolution up to 20ms, 10ms resolution up to 100ms and 20ms resolution up to 200ms) - Release time from 0.1 sec up to 3 sec (0.1 sec resolution) - Ratio from 1:1 to 32:1 (compressor only) - Adjustable soft or hard knee (compressor only)																								
Delay	380,998 ms 21 us increment/decrement steps per output channel only																								
Feedback Eliminator	Pitch shifting algorithm only for Mic input channels																								
Automixing Functions	NOM attenuation, Gain sharing algorithm and priority ducking processing																								
<b>GENERAL</b>	<table border="1"> <tr> <td>Device Presets</td> <td>6 user presets + 4 by using S1-S4 digital input ports</td> </tr> <tr> <td>Front Panel</td> <td>2 x 24 character LCD display with white/blue LED backlight - 6-LED status indicators (Line, Mic, Mute I/O, Signal, Clip, Limiter) 1-LED indicator Phantom power - 6 x front push button (Preset recall, Setup) - USB type B connector</td> </tr> <tr> <td>Rear Panel</td> <td>2 x 12 pin Phoenix connector (Mic/Line inputs) - 2 x 12 pin Phoenix connector (Line outputs) - 2 x 4 pin Phoenix connector (S1-S4 digital input ports - TTL level 0-5V) - 2 x 4 pin Phoenix connector (S1-S4 digital output ports - TTL level 0-5V) 2 x RJ45 for RS485 In/Out connection - 1 x RJ45 with activity leds for Ethernet connection (10/100 TCP-IP) - IEC C13 16A connector; power on/off switch</td> </tr> <tr> <td>Optional Device</td> <td>FBT WP8008 wall panel control</td> </tr> <tr> <td>Included Software</td> <td>PC users interface</td> </tr> <tr> <td>Main AC</td> <td>90-240Vac (50/60Hz) - 40W</td> </tr> <tr> <td>Dimensions</td> <td>mm 483x44x229 - 1RU</td> </tr> <tr> <td>Weight, Net/Shipping</td> <td>Kg 3.5 - 4</td> </tr> </table>	Device Presets	6 user presets + 4 by using S1-S4 digital input ports	Front Panel	2 x 24 character LCD display with white/blue LED backlight - 6-LED status indicators (Line, Mic, Mute I/O, Signal, Clip, Limiter) 1-LED indicator Phantom power - 6 x front push button (Preset recall, Setup) - USB type B connector	Rear Panel	2 x 12 pin Phoenix connector (Mic/Line inputs) - 2 x 12 pin Phoenix connector (Line outputs) - 2 x 4 pin Phoenix connector (S1-S4 digital input ports - TTL level 0-5V) - 2 x 4 pin Phoenix connector (S1-S4 digital output ports - TTL level 0-5V) 2 x RJ45 for RS485 In/Out connection - 1 x RJ45 with activity leds for Ethernet connection (10/100 TCP-IP) - IEC C13 16A connector; power on/off switch	Optional Device	FBT WP8008 wall panel control	Included Software	PC users interface	Main AC	90-240Vac (50/60Hz) - 40W	Dimensions	mm 483x44x229 - 1RU	Weight, Net/Shipping	Kg 3.5 - 4								
Device Presets	6 user presets + 4 by using S1-S4 digital input ports																								
Front Panel	2 x 24 character LCD display with white/blue LED backlight - 6-LED status indicators (Line, Mic, Mute I/O, Signal, Clip, Limiter) 1-LED indicator Phantom power - 6 x front push button (Preset recall, Setup) - USB type B connector																								
Rear Panel	2 x 12 pin Phoenix connector (Mic/Line inputs) - 2 x 12 pin Phoenix connector (Line outputs) - 2 x 4 pin Phoenix connector (S1-S4 digital input ports - TTL level 0-5V) - 2 x 4 pin Phoenix connector (S1-S4 digital output ports - TTL level 0-5V) 2 x RJ45 for RS485 In/Out connection - 1 x RJ45 with activity leds for Ethernet connection (10/100 TCP-IP) - IEC C13 16A connector; power on/off switch																								
Optional Device	FBT WP8008 wall panel control																								
Included Software	PC users interface																								
Main AC	90-240Vac (50/60Hz) - 40W																								
Dimensions	mm 483x44x229 - 1RU																								
Weight, Net/Shipping	Kg 3.5 - 4																								

# Control Unit



The basic AW25 card can be installed directly inside electrical junction boxes or in false ceilings, while models AW25-DIN and AW25R-DIN, supplied with their own boxes, are suitable for installation on standard DIN guides. Contacts for remote volume control are provided, and if necessary it is possible to set operation simply as a booster unit (maximum volume on switching on). In this way, the output power will be determined by the level of the input power. Model AW25R-DIN has a trimmer-type volume control built into the internal circuit. This enables local adjustment of the volume of

the two inputs, LEFT and RIGHT, in addition to any external volume controls. The ease of installation, the compact size and the high quality of these amplifiers make them particularly suitable for professional use for separate broadcasting of sound to small areas (e.g. TV signal in hotel rooms, booths of wellbeing centres, signals from video projectors/personal computers in meeting rooms) or for mobile applications such as amplification for market stalls, ships, buses, etc.



An interesting feature of these models is that it is possible to control the volume simply by means of remote push-buttons (similar to common electrical UP/DOWN push-buttons), enabling all sorts of possible uses and making it easy to build them into systems. It is also possible to switch on the amplifiers from a remote station

using a remote stand-by switch. A specific service output will enable activation of a signal confirming that they have switched on. These specifications, combined with the possibility of powering the amplifier from a source ranging from 12 to 24 VDC, ensure excellent flexibility and versatility of installation.





The models of the AW25 range are high-efficiency Class D stereo amplifiers. They are small and compact but extraordinarily powerful thanks to the high-quality components with which they are made. They are capable of high performance levels in terms of signal dynamics.

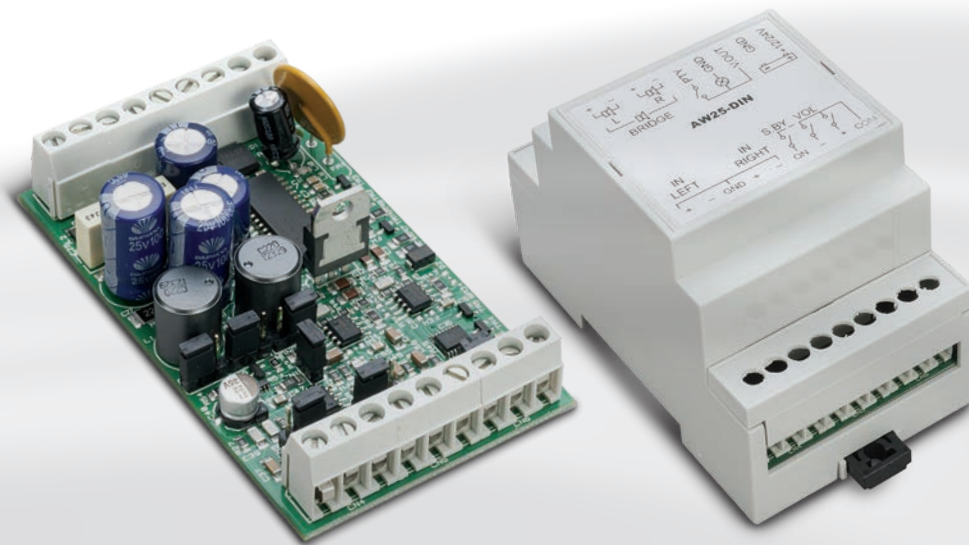

## AW 25      AW 25-DIN      AW 25R-DIN

### Code 39710

#### 25 W STEREO AMPLIFIER MODULE

- Class D stereo amplifier, 25 W maximum
- High-efficiency
- Small and compact sizes (AW25 card version or AW25-DIN and AW25R-DIN models with box suitable for installation on standard DIN guides)
- suitable for sound broadcasting to small areas (hotel rooms, booths of wellbeing centres, meeting rooms)
- 3 different operating modes: STEREO / BRIDGE / PA
- volume control simply by means of remote push-buttons
- 12 ÷ 24 Vdc power supply

#### OPERATING MODE

The unique feature of these amplifiers is that they can be used in three different modes, depending on requirements:

- **STEREO.** Amplifier with two stereo channels (L + R).
- **BRIDGE** (mono). Amplifier with a single channel featuring a higher output power (bridge connection). If a stereo source is connected to them, the Left and Right inputs are mixed.
- **PA** (mono). Amplifier with two independent channels, the first of which for background music and the second (priority) for calls, by activation from an external contact. The typical soundbroadcasting application for interrupting the background music, by means of a control, when a handsfree call is received.

### Code 39711

#### 25 W STEREO AMPLIFIER UNIT, STANDARD DIN GUIDES

### Code 39712

#### AS AW25-DIN WITH VOLUME CONTROL

### AW25 / AW25-DIN / AW25R-DIN

Code	39710 / 39711 / 39712			
Operating mode	2 Stereo Channels		2 Bridge Channels	
Output power at 12 Vdc (D= 1%)	RL=8Ω+8 Ω	1,5+1,5 W	RL = 8Ω	6 W
	RL=4Ω+4 Ω	2,5+2,5 W	RL = 4Ω	10 W
Output power at 24 Vdc (D= 1%)	RL=8Ω+8 Ω	7+7 W	RL = 8Ω	25 W
	RL=4Ω+4 Ω	11+11 W		
LINE input sensitivity (12 Vdc / 24 Vdc)	mV rms	150 / 300		
HIGH LEVEL input sensitivity	V rms	max 10		
S/N ratio @12 Vdc	dB	> 80		
S/N ratio @24 Vdc	dB	> 85		
Frequency response		60 ÷ 20.000 Hz (0 ÷ -3 dB)	40 ÷ 20.000 Hz (0 ÷ -3 dB)	
V.OUT output @12/24 Vdc	W	max 3		
Mains power supply	Vcc	11 (min) ÷ 28 (max)		
Maximum consumption @12/24 Vdc		@ 12/24 Vcc 1 A / 1,7 A		
Minimum consumption @12V/24 Vdc		@ 12V/24 Vcc 60 mA / 70 mA		
Stand-by consumption	mA	12		
Dimensions (WxHxD)	mm	AW25: 95x50x30 AW25-DIN e AW25R-DIN: 90x53x58		

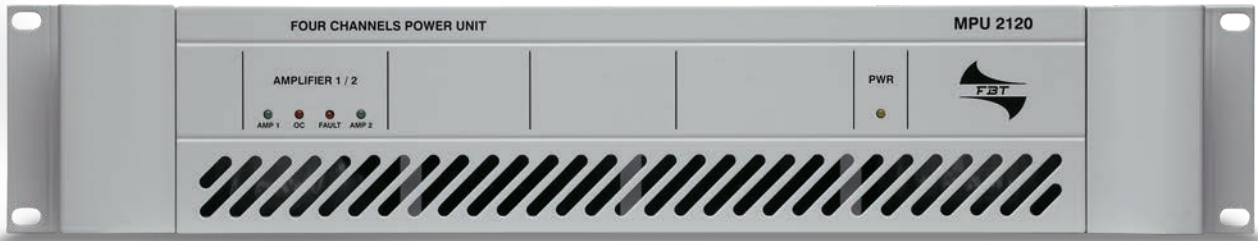

## MPU 2120

**Code 31080**

### MULTI CHANNEL 100V LINE POWER UNITS

- Output with transformers for 100V and 70V lines
- Frequency response 40Hz to 20kHz
- 40Hz internal high-pass filter
- Configurations: 2x120W, 1x240W
- Thermal and short-circuit protections
- 2 U rack

## MPU 4060

**Code 31079**

### MULTI CHANNEL 100V LINE POWER UNITS

Same features as the MPU 2120 model except for the following difference:

- Configurations: 4x60W, 2x120W

## MPU 4120

**Code 31059**

### MULTI CHANNEL 100V LINE POWER UNITS

- Output with transformers for 100V and 70V lines
- Frequency response 40Hz to 20kHz
- 40Hz internal high-pass filter
- Configurations: 4x120W, 2x240W
- Thermal and short-circuit protections
- 2 U rack

## MPU 4240

**Code 31078**

### MULTI CHANNEL 100V LINE POWER UNITS

Same features as the MPU 2120 model except for the following difference:

- Configurations: 4x240W, 2x480W

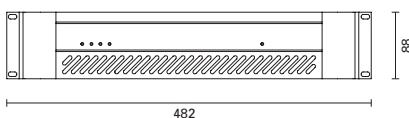



		<b>MPU 2120</b>	<b>MPU 4060</b>	<b>MPU 4120</b>	<b>MPU 4240</b>
<b>Code</b>		<b>31080</b>	<b>31079</b>	<b>31059</b>	<b>31078</b>
Features		2-channel monoblock amplifier	4-channel monoblock amplifier	4-channel monoblock amplifier	4-channel monoblock amplifier
Output power of all the driven channels		2x120Wrms 100V/70V 1x240Wrms 100V	4x60Wrms 100V/70V 2x120Wrms 100V	4x120Wrms 100V/70V 2x240Wrms 100V	4x240Wrms 100V/70V 2x480Wrms 100V
Frequency response		40Hz÷20kHz 40Hz internal high-pass filter	40Hz÷18kHz 40Hz internal high-pass filter	40Hz÷20kHz 40Hz internal high-pass filter	40Hz÷20kHz 40Hz internal high-pass filter
Signal/noise ratio	dB	96 (with filter 22Hz÷22kHz)	96 (with filter 22Hz÷22kHz)	96 (with filter 22Hz÷22kHz)	96 (with filter 22Hz÷22kHz)
Separation between channel	dB	> 80	> 80	> 80	> 80
THD+D@1W/8ohm		0,005%	0,004%	0,005%	0,005%
Inputs		balanced with screw connector	balanced with screw connector	balanced with screw connector	balanced with screw connector
Input sensitivity	dBu	0 (0.775V) balanced 6 (1.5V) unbalanced	0 (0.775V) balanced 6 (1.5V) unbalanced	0 (0.775V) balanced 6 (1.5V) unbalanced	0 (0.775V) balanced 6 (1.5V) unbalanced
Input impedance	kohm	20 balanced 10 unbalanced	20 balanced 10 unbalanced	20 balanced 10 unbalanced	20 balanced 10 unbalanced
Controls		Volume control for each channel located in the back panel	Volume control for each channel located in the back panel	Volume control for each channel located in the back panel	Volume control for each channel located in the back panel
Light indicators		Input signal presence for each OC (over current) channel and Fault every two channels	Input signal presence for each OC (over current) channel and Fault every two channels	Input signal presence for each OC (over current) channel and Fault every two channels	Input signal presence for each OC (over current) channel and Fault every two channels
Power supply Vac	Vac	Internal setting 85÷132 170÷264 (De Fault)	Internal setting 85÷132 170÷264 (De Fault)	Internal setting 85÷132 170÷264 (De Fault)	Internal setting 85÷132 170÷264 (De Fault)
Absorption	VA	300 (@ max power with music signal)	250 (@ max power with music signal)	600 (@ max power with music signal)	1200 (@ max power with music signal)
Operating conditions	°C	-20+40 with max. humidity <90%	-20+40 with max. humidity <90%	-20+40 with max. humidity <90%	-20+40 with max. humidity <90%
Protections		Short-circuit (OC), thermal (Fault)	Short-circuit (OC), thermal (Fault)	Short-circuit (OC), thermal (Fault)	Short-circuit (OC), thermal (Fault)
Cooling		1 ø 60mm fan	1 ø 60mm fan	1 ø 60mm fan	1 ø 60mm fan
Dimensions (WxHxD)	mm	482x88x430 (2 U rack)	482x88x430 (2 U rack)	482x88x430 (2 U rack)	482x88x430 (2 U rack)

# 68 | Power Amplifier and Music Sources



## MPA 5120

## MPA 5240

## MPA 5480

Code 37490

Code 37489\*

Code 37491\*

### CLASS D MODULAR AMPLIFIER

This is a new range of power units designed specifically for professional sound-broadcasting systems with service and emergency messages. Thanks to the great reliability of the protection circuits used, combined with an attractive appearance and the very tough structures, the MPA range constitutes the ideal product for quality amplification, with a particularly interesting price/ performance ratio. If this amplifier is used in emergency systems, it is possible to disable all the front-panel controls (tone and volume controls). In this way it is possible to prevent the levels set at the time of commissioning the system from being altered accidentally.

\*Technical specifications page 17

- Balanced line input/output (XLR-F and XLR-M sockets, with adjustable sensitivity)
- Unbalanced line input (double RCA socket)
- MBT 1101 microphone station input (RJ45 socket)
- Telephone/emergency audio input for priority calls with adjustable threshold and sensitivity
- Front panel overall volume control and treble and bass controls
- Rear-panel selector switch for enabling/disabling front-panel tone and volume controls
- Constant voltage (50/70/100 V) or 8  $\Omega$  impedance loudspeaker line output.
- LED-type Vu meter for clear and immediate monitoring of output power
- Contacts for activating precedence on line input
- Alerting signal (chime) with level control
- Selectable 230/115 VAC and 24 VDC mains power supply

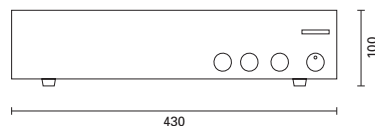



## AM 5030

Code 11583

### 30W INTEGRATED AMPLIFIER

- 2 microphone sockets
- Priority of microphone over music
- Low impedance and 100V outputs
- 2 rack units

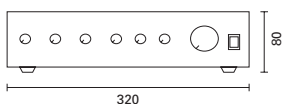

# 70 | Power Amplifier and Music Sources



## MXA 1060

Code 37638

## MXA 1120

Code 37639

### INTEGRATED AMPLIFIERS

- 2 microphone inputs with phantom power supply (XLR). MIC 1 with automatic precedence function (VOX) and threshold adjustment control
- Microphone input (XLR) with phantom power supply or RJ45 for connecting up to 6 MBT 1101 microphone stations (maximum distance 200 m)
- MIC/PH/LINE input with associated selector switch 2 auxiliary inputs for sound sources (TAPE/CD)
- Telephone/emergency audio input for priority calls with adjustable threshold and sensitivity
- Front-panel level control for each microphone and auxiliary input
- Front panel overall volume control and treble and bass controls
- Constant voltage (50/70/100 V) or 8  $\Omega$  impedance loudspeaker line output
- Auxiliary line output
- LED-type Vu meter for immediate monitoring of output power
- Microswitches for setting priorities and input functions
- Inclusion/exclusion of speech filter on all microphone inputs
- Contacts for activating input precedence
- Alerting signal (chime) with level control
- Selectable 230/115 VAC and 24 VDC mains power supply

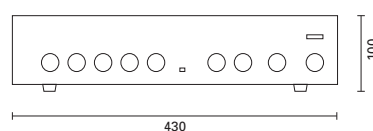
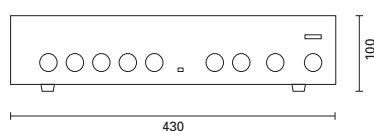



## MXA 3120

Code 37640

### INTEGRATED AMPLIFIERS

- 2 balanced/unbalanced microphone inputs with phantom power supply
- Microphone input or microphone stations of the MBT 1000 range
- 2 MIC/PH/LINE inputs with specific selector switch
- 2 auxiliary inputs for sound sources (TAPE/CD)
- Telephone/emergency audio input for priority calls with adjustable threshold and sensitivity
- Front-panel adjustment of the level of each microphone and auxiliary input
- Front-panel control of overall volume and of treble and bass tones
- Provisions for inserting via the front panel a USB/SD CARD module ( )
- Constant voltage (50/70/100 V) or 8  $\Omega$  impedance loudspeaker line output
- 3 output lines for zones
- Balanced line output for connection to other amplifiers
- Output/input for connection to audio processors
- LED-type Vu meter for clear and immediate reading of power emitted
- Microswitches for setting operating modes
- Includable/excludable speech filters on all microphone inputs
- Contacts for activating input precedence and override
- "Music On Hold" output with output level control (output of the selected auxiliary signal)
- Alerting signal (chime) with level control
- Front-panel keys for selecting music listening zones
- Selectable mains power supply - 230/115 VAC or 24 VDC

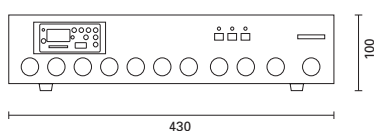

## MXA 3240

Code 37641

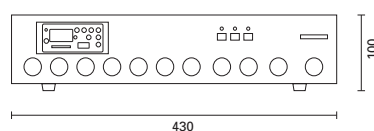

## USB 3000

USB/SD CARD Module

Code 37642

# 72 | Power Amplifier and Music Sources



## MDS 1060

Code 37495

## MDS 1120

Code 37496

## MDS 1240

Code 37497

### MUSIC DISTRIBUTION SYSTEM

The **MDS 1000** compact systems combine a reliable amplifier, an MP3 player, an SD/MMC card drive, a USB socket for connection to external storage units and a digital FM tuner in a single piece of equipment that also features a range of functions typical of sound-broadcasting systems. The XLR sockets on the rear panel can be separately configured as microphone inputs (with or without phantom power supply) or as line inputs. The operating mode can be selected by means of the specific three-position switches above the sockets. Each of these inputs has its own level control so as to be able to adjust the amplitude of the various different signals suitably. In addition, the MIC/LINE 1 microphone input has an automatic precedence function (VOX): when speaking with the microphone connected to this input, all the music and microphone inputs will be automatically muted. It is possible to connect all dynamic microphones and the MBT 6400S microphone bases to the MDS 1000 Compact Systems.

- MP3 file player via USB, SD or MMC card
- FM digital tuner
- n°3 MIC./LINE inputs with operating mode selector switches.
- n°1 VOX input (MIC/LINE 1)
- n°1 auxiliary input for sound sources (TAPE/CD)
- XLR sockets for connection to dynamic microphones and/or MBT 6400S microphone bases
- Terminal strip for speakers output (25-70-100V/4ohm)
- Terminal strip for external 24 Vdc power supply
- Terminal strip for microphone precedence
- Possibility to connect an external equalizer and/or booster
- Selectable mains power (230/120Vac)

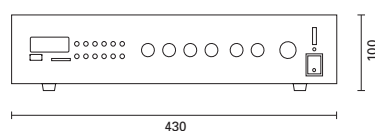





## MDS 6120

## MDS 6240

Code 37643

Code 37644

### MUSIC DISTRIBUTION SYSTEM

- 2 balanced/unbalanced microphone inputs with phantom power supplies
- Microphone input or microphone bases of the MBT 1000 range
- 2 MIC/PH/LINE inputs with associated selector switch
- 2 auxiliary inputs for sound sources (TAPE/CD)
- Telephone/emergency audio input for priority calls with adjustable threshold and sensitivity
- Front-panel level controls for each microphone and auxiliary input
- Front panel overall volume control and treble and bass controls
- Multi-purpose sound source module with CD-MP3/ USB/SD CARD player and AM/FM tuner.
- Constant voltage (50/70/100 V) or 8Ω impedance loudspeaker output lines
- 6 output lines (zones) with front-panel level control for the music signal for each single zone
- Balanced line output for connection to other amplifiers
- Output/input for connection to audio processors
- Connection to an external amplifier for simultaneous music and speech in different zones
- LED-type Vu meter for clear and immediate monitoring of output power
- Microswitches for setting the operating modes
- Inclusion/exclusion of speech filter on all microphone inputs
- Contacts for activating input precedence and override
- "Music On Hold" output with output level control (output of selected auxiliary signal)
- Alerting signal (chime) with level control
- Selectable 230/115 VAC and 24 VDC mains power supply

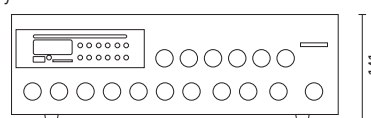
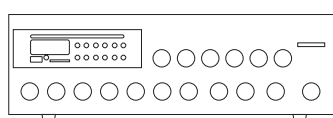

432

432

# Power Amplifier and Music Sources



		MPA 5120	AM 5030	MXA 1060	MXA 1120	MXA 3120	MXA 3240
<b>Code</b>		<b>37490</b>	<b>11583</b>	<b>37638</b>	<b>37639</b>	<b>37640</b>	<b>37641</b>
Rated Output power	W	120	30/40	60	120	120	240
Constant voltage output / low impedance output		100-70-50 V e 8 Ω	-	100-70-50 V e 8 Ω	100-70-50 V e 8 Ω	100-70-50 V e 8 Ω	100-70-50 V e 8 Ω
Tones control	dB	Bass ± 10 (100 Hz) Treble ± 10 (10 kHz)	-	Bass ± 10 (100 Hz) Treble ± 10 (10 kHz)	Bassi± 10 (100 Hz) Treble± 10 (10 kHz)	Bass ± 10 (100 Hz) Treble ± 10 (10 kHz)	Bass ± 10 (100 Hz) Treble ± 10 (10 kHz)
MIC. 1 and MIC. 2 inputs		-	-	2 balanced, XLR (phantom power 17,5 V) MIC1 with priority activation	2 balanced, XLR (phantom power 17,5 V) MIC1 with priority activation	2 balanced, XLR (phantom power 17,5V) MIC1 with priority activation	2 balanced, XLR (phantom power 17,5V) MIC1 with priority activation
Sensitivity/impedance		-	-	0,9 mV / 900 Ω	0,9 mV / 900 Ω	0,9 mV / 900 Ω	0,9 mV / 900 Ω
S/N ratio	dB	-	-	>62	>62	>62	>62
MIC. 3 / UNITS input		-	-	balanced, XLR (phantom power) Rj45 (MBT 1101)	balanced, XLR (phantom power) Rj45 (MBT 1101)	balanced, XLR (phantom power) Rj45 (MBT 1101)	balanced, XLR (phantom power) Rj45 (MBT 1101)
Sensitivity/impedance		-	-	MIC.: 0,9mV / 900 Ω - UNITS: 290 mV / 700 k Ω	MIC.: 0,9mV / 900 Ω - UNITS: 290 mV / 700 k Ω	MIC.: 0,9mV / 900 Ω - UNITS: 290 mV / 700 k Ω	MIC.: 0,9mV / 900 Ω - UNITS: 290 mV / 700 k Ω
S/N ratio	dB	-	-	MIC.: >62 UNITS: >65	MIC.: >62 UNITS: >65	MIC.: >62 UNITS: >65	MIC.: >62 UNITS: >65
Number of consoles of MBT 1101		-	-	Max 6 consoles in daisy chain max distance 200 mt	Max 6 consoles in daisy chain max distance 200 mt	Max 6 consoles in daisy chain max distance 200 mt	Max 6 consoles in daisy chain max distance 200 mt
MIC / LINE 4 and 5		-	-	balanced, XLR with Phantom selector/ Mic/Line	balanced, XLR with Phantom selector/ Mic/Line	2 balanced, XLR with Phantom selector/ Mic/Line	2 balanced, XLR with Phantom selector/ Mic/Line
Sensitivity/impedance		-	-	MIC: 0,9 mV / 900 Ω - LINE: 90 mV / 50 kΩ	MIC: 0,9 mV / 900 Ω - LINE: 90 mV / 50 kΩ	MIC: 0,9 mV / 900 Ω - LINE: 90 mV / 50 kΩ	MIC: 0,9 mV / 900 Ω - LINE: 90 mV / 50 kΩ
S/N ratio	dB	-	-	MIC: >62 LINE: >70	MIC: >62 LINE: >70	MIC: >62 LINE: >70	MIC: >62 LINE: >70
In UNITS		RJ45 (MBT 1101)	-	-	-	-	-
Sensitivity/impedance	mV	1250	-	-	-	-	-
S/N ratio	dB	> 78	-	-	-	-	-
Frequency response	Hz	30 ÷ 20.000	-	-	-	-	-
Number of consoles of MBT 1101		Max 6 consoles in daisy chain max distance 200 mt	-	-	-	-	-
Line input		balanced XLR, unbalanced RCA	-	-	-	-	-
Sensitivity/impedance		300 mV / 60 kΩ	-	-	-	-	-
S/N ratio	dB	>77	-	-	-	-	-
Frequency response	Hz	30 ÷ 20.000	-	-	-	-	-
Auxiliary input		-	-	2 unbalanced, RCA (CD, TAPE)	2 unbalanced, RCA (CD, TAPE)	2 unbalanced, RCA (CD, TAPE)	2 unbalanced, RCA (CD, TAPE)
Sensitivity/impedance		-	-	150 mV / 6 kΩ	150 mV / 6 kΩ	150 mV / 6 kΩ	150 mV / 6 kΩ
S/N ratio	dB	-	-	>70	>70	>70	>70
Telephone input		balanced with priority activation	-	balanced with priority activation	balanced with priority activation	balanced with terminal for priority activation	balanced with terminal for priority activation
Sensitivity/impedance		120 mV / 6 kΩ	-	150 mV / 6 kΩ	150 mV / 6 kΩ	150 mV / 6 kΩ	150 mV / 6 kΩ
S/N ratio	dB	>75	-	> 72	> 72	> 72	> 72
Frequency response	Hz	230 ÷ 13.000	-	-	-	-	-
Line out		balanced, XLR	-	900mV / 100 Ω unbalanced, RCA	900mV / 100 Ω unbalanced, RCA	900mV / 100 Ω, unbalanced RCA	900mV / 100 Ω, unbalanced RCA
Power supply		230/115 Vca 50/60 Hz / 24 Vcc	220Vac	230/115 Vca 50/60 Hz / 24 Vcc	230/115 Vca 50/60 Hz / 24 Vcc	230/115 Vca 50/60 Hz / 24 Vcc	230/115 Vca 50/60 Hz / 24 Vcc
Max power consumption		280 W (320 VA)	-	130 W (150 VA)	270 W (320 VA)	130 W (150 VA)	270 W (320 VA)
External 24 Vcc power supply	A	6,6 / 0,2	-	3,4 / 0,1	6,7 / 0,2	3,4 / 0,1	6,7 / 0,2
Rack dimensions 19"		Optional bracket RMK 5000	-	Optional bracket RMK 5000	Optional bracket RMK 5000	Optional bracket RMK 5000	Optional bracket RMK 5000
Dimensions (WxHxD)	mm	432x88x272	320x80x190	430x88x234	430x88x234	430x88x234	430x88x234
Weight	Kg	8,2	4,7	6,5	9	6,5	9



		<b>MDS 1060</b>	<b>MDS 1120</b>	<b>MDS 1240</b>	<b>MDS 6120</b>	<b>MDS 6240</b>
<b>Code</b>		<b>37495</b>	<b>37496</b>	<b>37497</b>	<b>37643</b>	<b>37644</b>
Rated Output power	W	60 W	120 W	240 W	120 W	240 W
Constant voltage output / low impedance output	v	100, 70, 25 x - 4 ohm	100, 70, 25	100, 70, 25	100-70-50 e 8 Ω	100-70-50 e 8 Ω
Tones control	dB	Bass ± 12 (100 Hz) Treble ± 11 (10 kHz)	Bass ± 12 (100 Hz) Treble ± 11 (10 kHz)	Bass ± 12 (100 Hz) Treble ± 11 (10 kHz)	Bass ± 10 (100 Hz) Treble ± 10 (10 kHz)	Bass ± 10 (100 Hz) Treble ± 10 (10 kHz)
MIC. 1 and MIC. 2 inputs		-	-	-	2 balanced, XLR (phantom power 17,5 V) MIC1 with priority activation	2 balanced, XLR (phantom power 17,5 V) MIC1 with priority activation
Sensitivity/impedance		-	-	-	1,2 mV / 1300 Ω	1,2 mV / 1300 Ω
S/N ratio	dB	-	-	-	> 66	> 66
MIC. 3 / UNITS input		-	-	-	balanced, XLR (phantom power 17,5 V) / 1 Rj45 (MBT1106)	balanced, XLR (phantom power 17,5 V) / 1 Rj45 (MBT1106)
Sensitivity/impedance		-	-	-	MIC: 1,2 mV / 1,3 kΩ UNITS: 850mV / 800 kΩ	MIC: 1,2 mV / 1,3 kΩ UNITS: 850mV / 800 kΩ
S/N ratio	dB	-	-	-	MIC: >66 UNITS: >76	MIC: >66 UNITS: >76
Number of consoles of MBT 1106		-	-	-	Max 8 consoles in daisy chain max distance 1 km	Max 8 consoles in daisy chain max distance 1 km
MIC / LINE 4 and 5		-	-	-	2 balanced XLR Phantom selector/Mic/Line	2 balanced XLR Phantom selector/Mic/Line
Sensitivity/impedance		-	-	-	MIC: 1,2 mV / 1,3 kΩ LINE: 110 mV / 130 kΩ	MIC: 1,2 mV / 1,3 kΩ LINE: 110 mV / 130 kΩ
S/N ratio	dB	-	-	-	MIC: >66 LINE: >77	MIC: >66 LINE: >77
Microphone/line inputs						
Sensitivity/impedance		MIC: 3 mV / 1,5 Ω LINE: 250 mV / 100 kΩ	MIC: 3 mV / 1,5 Ω LINE: 250 mV / 100 kΩ	MIC: 250 mV / 100 kΩ LINE: 250 mV / 100 kΩ	-	-
S/N ratio	dB	68	70	76	-	-
S/N ratio ('A' weighted)	dBA	73	73	82	-	-
MIC/line 1 VOX activation threshold	mV	0,9	0,9	-	-	-
Frequency response	Hz	35÷16.000	35÷16.000	35÷16.000	-	-
Phantom supply		18 V / 2,2 kohm	18 V / 2,2 kohm	18 V / 2,2 kohm	-	-
Auxiliary input		-	-	-	2 RCA (CD + TAPE)	2 RCA (CD + TAPE)
Sensitivity/impedance		400 mV/22 kohm	400 mV/22 kohm	400 mV/22 kohm	CD: 450 mV / 35 kΩ ; TAPE: 220 mV / 18 kΩ	CD: 450 mV / 35 kΩ ; TAPE: 220 mV / 18 kΩ
S/N ratio	dB	78	80	80	> 80 dB	> 80 dB
Telephone input		-	-	-	Balanced with terminals for priority activation	balanced with terminals for priority activation
Sensitivity/impedance		-	-	-	105 mV / 6 kΩ	105 mV / 6 kΩ
S/N ratio		-	-	-	> 74 dB	> 74 dB
Frequency response		-	-	-	200 ÷ 20.000 Hz	200 ÷ 20.000 Hz
Line out		1 V / 200 ohm	1 V / 200 ohm	1 V / 200 ohm	5	5
Power supply		P = 150 W	P = 300 W	P = 600 W	230/115 VCA 50/60 Hz / 24 Vcc	230/115 VCA 50/60 Hz / 24 Vcc
Max power consumption		-	-	-	280 W (325 VA)	510 W (590 VA)
External 24 Vcc power supply		-	-	-	6,8 A / 0,2 A	13,1 A / 0,3 A
Rack dimensions 19"		-	-	-	Optional brackets	Optional brackets
Dimensions (WxHxD)	mm	430x88x270	430x88x270	430x88x270	432x133x360	432x133x360
Weight	Kg	6,3	8,3	8,3	14	16,5



MS02 CD3/T



MS02 CD/DG

## MS02 CD3/T

Code 27867

### MUSIC SOURCES

#### Dual source

- 2 sections, each one featuring a stereo output with its own volume control
- One selector, shared by both sources, can mix stereo channels changing to MONO the CD and radio output for applications that do not need stereo sound
- It can be installed into a 19" rack 1U
- The CD player can play audio tracks and MP3 files from compact disc (CD, CD-R, CD-R/W) or USB drives ("Flash memory-stick with mp3 files)
- USB port on the front panel
- FM radio tuner (87.5-108 MHz) that can store up to 10 radio stations
- LCD display



Remote control included with MS02 CD3/T

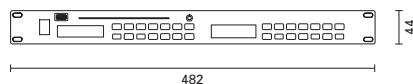

## MS02 CD3/DG

Code 27868

### MUSIC SOURCES

#### Dual sound source system composed of:

- USB & SD Card Reader and Recorder / Remote Control
- Recording through the Line-in is directly store to USB or SD Card
- Offers USB and SD Card function of each replication
- Recording format: MP3
- Playing format: MP3, WMA
- Accept the capacity of 128MB to 16G USB or SDHC Card
- With a language learning function, can be broadcast repeatedly at designated areas
- Adjustable recording quality, provide choice of, 128Kbps and 192Kbps

#### Anti Shock CD / USB & SD Card Reader / Remote Control

- Offers USB, SD Card and CD playing function of each replication
- Playing format: MP3, WMA
- Accept the capacity of 128MB to 16G USB or SD Card
- With a language learning function, can be broadcast repeatedly at designated area

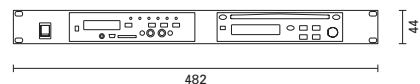



MS02 CD3/T	
<b>Code</b>	<b>27867</b>
Tuner	AM/FM
Memories for the tuner (FM10 e AM10)	20
Mechanics	Antishock mechanics and electronics CD player that can play CD, CD-R, CD-RW, MP3, USB MP3
Inputs/Outputs	Input: unbalanced 75ohm FM Antenna terminals AM antenna loop terminals USB port for memory stick Output: audio RCA for AM/FM tuner Audio RCA for CD player
Power supply	Vac 220
Power consumption	VA 50
Dimensions (WxHxD)	mm 482x44x250
Peso	Kg 3,5



MS02 CD3/DG	
<b>Code</b>	<b>27867</b>
Mains power supply	230 VAC ±10% 50/60 Hz
DC External power supply	VDC 24
Mains consumption	VA 45
DC consumption	mA 700 (max)
CD/USB/SD player output level	mV 250
USB/SD reader & recorder output level	mV 900
Weight	mm 482x44x285
Dimensions (WxHxD)	Kg 4,5

# 78 | Rack and Cabinets

The racks of the P5800-D and P5800-L range comply with **IEC 297-2** and **CEI EN 60065** standards. Also, as called for in the general safety regulations for electrical systems (**CEI 64-8, CEI 64-11, CEI 23-48**), both the racks and the various different accessories (doors, closing panels, etc.) are equipped with the appropriate terminals for connection to earth.



## P5800-D

## P5800-L

### RACK CABINETS

all the models of the P5800-D and P5800-L range are made of thick reinforced steel sheeting and are available in black. A mounting kit consisting of:

- Two sides with ventilation slits

- An upper closing panel and a lower one
- Four feet
- Set of screws for mechanical assembly
- Four cables with lugs on the ends for

- connecting the equipment to earth
- Set of caged nuts for securing the service equipment

Black front window panels with double locks are available for

opening to the right or to the left (P5700 range). As an alternative to the normal rear closing panels secured by screws, black blind rear doors with locks and ventilation slits are also available (P5400-D range).

	P5808	P5812-D	P5816-D	P5820-D	P5824-D	P5830-D	P5840-D	P5828-L	P5836-L	P5842-L
<b>Code</b>	<b>40121</b>	<b>40929</b>	<b>41352</b>	<b>42328</b>	<b>42296</b>	<b>38674</b>	<b>40873</b>	<b>42652</b>	<b>42653</b>	<b>42654</b>
Modular units	8 U	12 U	16 U	20 U	24 U	30 U	40 U	28 U	36 U	42 U
Technical specifications	19" standard rack consisting of two sides with ventilation slits, an upper closing panel and a lower one, a set of screws for mechanical assembly, 4 cables with lugs on the ends for connecting the equipment to earth and a set of caged nuts for securing the service equipment.									
Width	52,5 cm	52,5 cm	52,5 cm	52,5 cm	52,5 cm	52,5 cm	52,5 cm	52,5 cm	52,5 cm	52,5 cm
Depth	45,6 cm	52,5 cm	52,5 cm	52,5 cm	52,5 cm	52,5 cm	52,5 cm	65 cm	65 cm	65 cm
Height	40,8 cm	58,6 cm	76,4 cm	94,2 cm	112 cm	138,6 cm	183,1 cm	129,8 cm	165,3 cm	192 cm
Front window door <b>Code</b>	-	P5712 <b>40930</b>	P5716 <b>41353</b>	P5720 <b>42329</b>	P5724 <b>42297</b>	P5730 <b>41380</b>	P5740 <b>40874</b>	P5728-L <b>42649</b>	P5736-L <b>42650</b>	P5742-L <b>42651</b>
Rear door <b>Code</b>	-	-	P5416-D <b>41354</b>	P5420-D <b>42330</b>	P5424-D <b>42331</b>	P5430-D <b>41381</b>	P5440-D <b>40875</b>	P5428-D <b>42646</b>	P5436-D <b>42647</b>	P5442-D <b>42648</b>
Rear closing panel <b>Code</b>	P5404-D (4 U) - P5408-D (8 U) - P5410-D (10 U) <b>41355 - 42332 - 42333</b>									
Colour	Black									
Weight	13,35 kg	17,9 kg	21,2 kg	24,8 kg	28,3 kg	33,2 kg	41,6 kg	30,7 kg	38,2 kg	44,6 kg

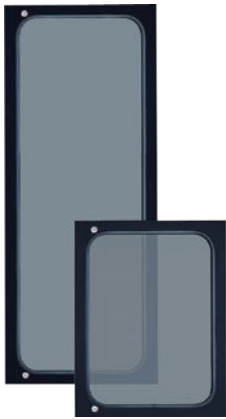

P5712 (12U)  
**Code 40930**

P5716 (16U)  
**Code 41353**

P5720 (20U)  
**Code 42329**

P5724 (24U)  
**Code 42297**

P5730 (30U)  
**Code 41380**

P5740 (40U)  
**Code 40874**



P8032  
**Code 42335**  
Drawer for accessories (3U)

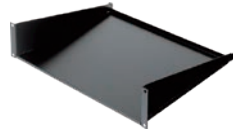

P8035  
**Code 40877**  
Top for supporting audio-video sources and various types of equipment (adaptable 2,3 and 4U)

## REAR CLOSING PANELS



P5404-D (4U)  
**Code 41355**



P5408-D (8U)  
**Code 42332**



P5410-D (10U)  
**Code 42333**

## ACCESSORIES



AC50  
**Code 38678**  
Pair of side brackets



AC54-D  
**Code 41356**  
Kit consisting of four wheels, load-bearing capacity 65 Kg each



AC5801-D  
**Code 41382**  
Foundation base for cabinets with cable output

## REAR DOORS



P5416-D (16U)  
**Code 41354**

P5420-D (20U)  
**Code 42330**

P5424-D (24U)  
**Code 42331**

P5430-D (30U)  
**Code 41381**

P5440-D (40U)  
**Code 40875**

## CLOSING PANELS

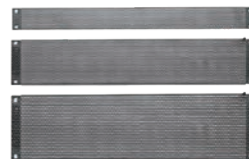

**PERFORATED PANELS**  
equipped with earth terminals

P5201-D (1 modular unit)  
**Code 38679**

P5202-D (2 modular units)  
**Code 38681**

P5203-D (3 modular units)  
**Code 42338**



**BLIND PANELS**  
Equipped with earth terminals

P8011-D (1 modular unit)  
**Code 38680**

P8012-D (2 modular units)  
**Code 40876**

P8013-D (3 modular units)  
**Code 41383**

P8014-D (4 modular units)  
**Code 40878**



## SAFE 10 PT

**Code 09356**

**DNH SURFACE MOUNTING SELF-EXTINGUISHING  
POLYCARBONATE WALL LOUDSPEAKER**

- Power 10 Watt
- 100V transformer
- SPL 1W/1m 85dB
- Dispersion (-6dB) 1kHz/4kHz 140°/100°
- Grey RAL7035 colour

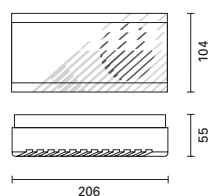

## WCS 650

**Code 29470**

**ABS CEILING/WALL  
MOUNTING SPEAKER**

- 10Watt dual cone loudspeaker with 153 g ferrite magnet
- 70V/100V line transformer and loudspeaker with 6,5" cone
- Easy mounting with the supports included

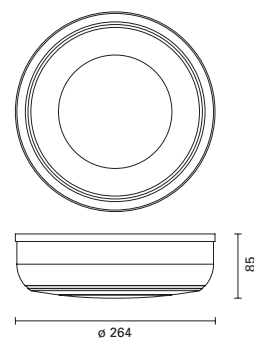



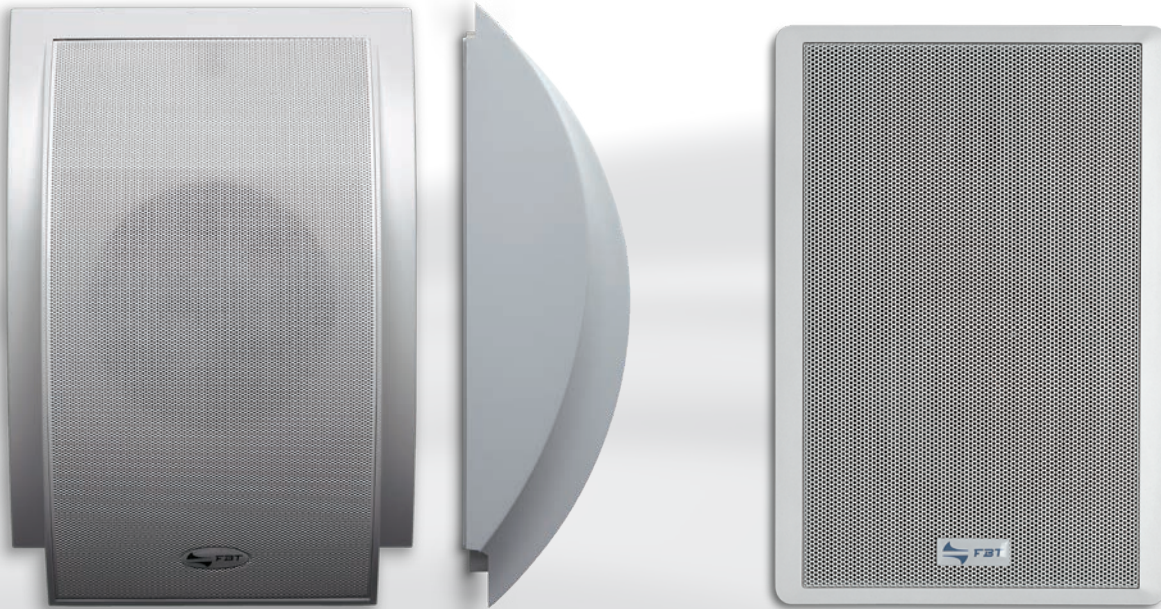

## WSH 1006

**Code 29419**

### ABS WALL MOUNTING SPEAKER WITH PAINTED METAL PROTECTIVE GRILLE

- 6 Watt dual cone loudspeaker
- Mounted horizontally or vertically
- 100V line transformer
- Easy mounting thanks to the hole cover plugs provided

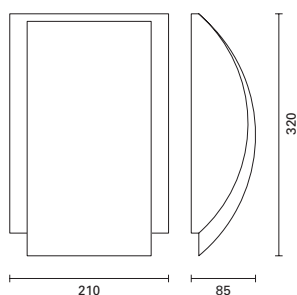

## FPS/505T

**Code 35302**

### ABS WALL MOUNTING SPEAKER

- 2-way
- Rated power 10W (20W max) at 4 Ohm
- Dispersion (-6dB) 1kHz/4kHz 150°/70°
- Power 10 Watt with 100V transformer
- Woofer 5" 1/4 with dome tweeter
- SPL @1W/1m 90dB
- White colour

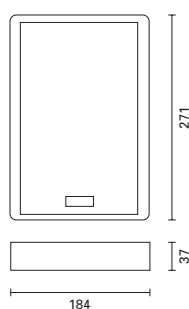

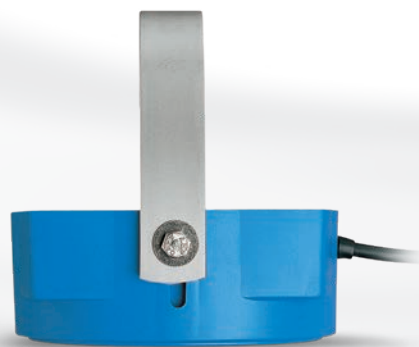

## ACQUA 30

**Code 10436**

**DNH ABS WALL OR SURFACE MOUNTED  
LOUDSPEAKER FOR UNDERWATER APPLICATIONS**

- IP68 grade of protection
- Rated power 20W at 8 Ohm
- Max/min operating temperature 90 C°/-30°C
- Dispersion (-6dB) 1kHz/4kHz 180°/180°
- SPL 1W/1m 105dB
- Guarantees superb audio quality for the reproduction of music and speech in underwater environments, positioned at a max of 2 metres below the water's surface

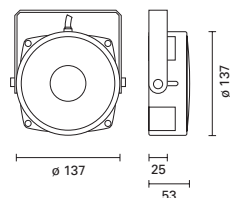

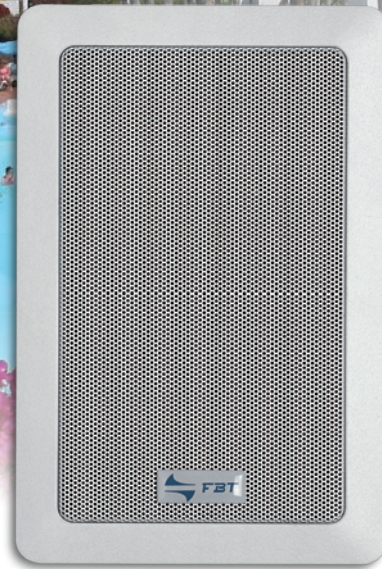

## IW 105T

**Code 30154**

### ABS SURFACE MOUNTING CEILING LOUDSPEAKER

- 2-way with 4" woofer and 1" dome tweeter
- Rated power 1/2/4/7.5/15W RMS with 100V transformer
- Frequency response 60-20,000Hz, sensitivity @1W/1m of 88dB
- Dispersion (-6dB) 1kHz/4kHz 80°/150°

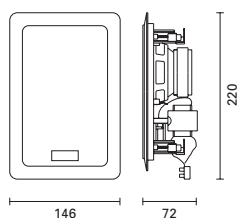

### RB-100

Surface mounting recess

**Code 18159**

For IW-100 TCP speakers

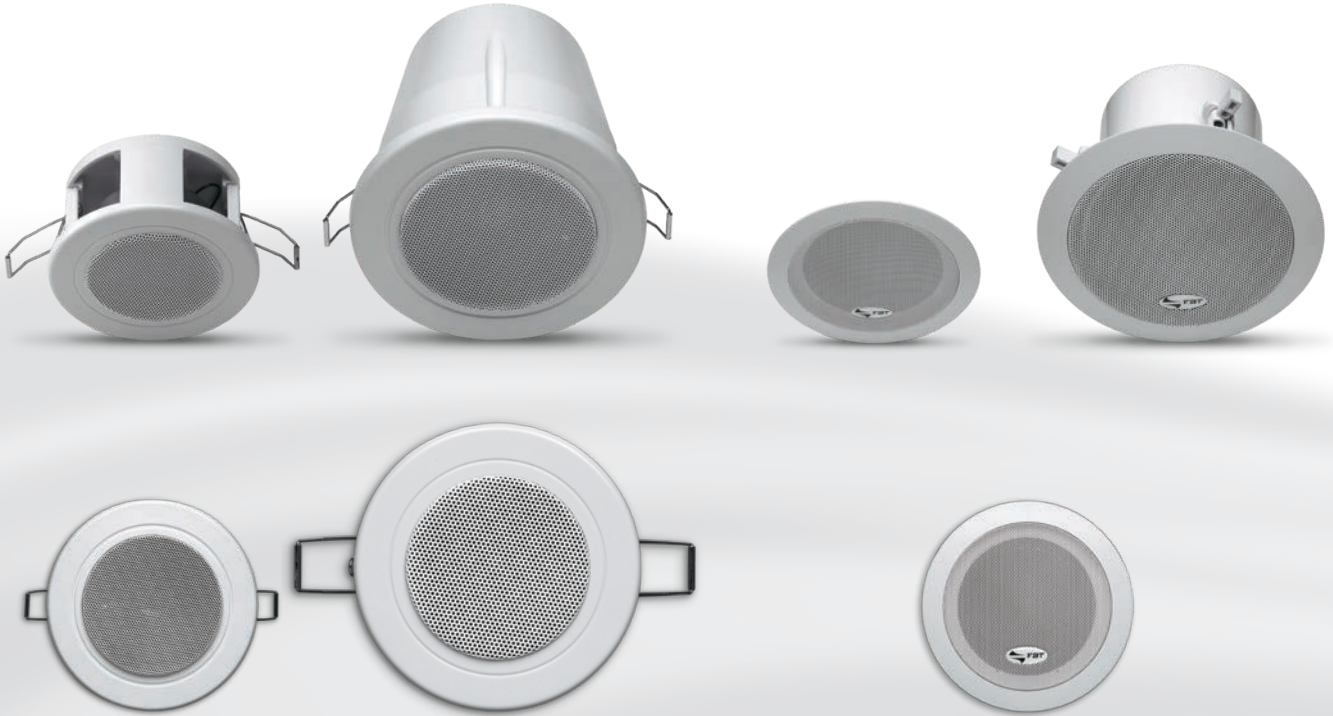

### **MCSL 006 TW**

**Code 29425**

**ABS IN-CEILING  
SPEAKER WITH  
METAL GRILLE**

- Colour white RAL9016
- Full range 2,5" dual cone

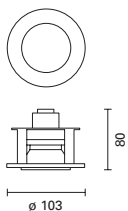

### **MCSL 006 TWP**

**Code 29426**

**ABS WEATHER-PROOF  
IN-CEILING SPEAKER  
WITH METAL GRILLE**

- ABS back cover equipped with cable sleeve to ensure good sealing
- Colour white RAL9016
- Full range 4" dual cone

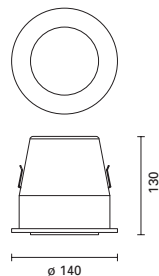

### **CSL 106/T**

**Code 29427**

**IN-CEILING SPEAKER  
WITH METAL  
GRILLE**

- Colour white RAL9016
- 5" dual cone loudspeaker

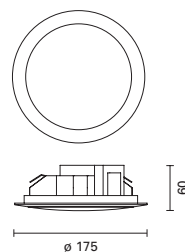

### **CSL 520 TIC**

**Code 29416**

**IN-CEILING SPEAKER  
WITH METAL  
GRILLE**

- Metal back cover
- Colour white RAL9016,
- Coaxial loudspeaker with 5" woofer and 1/2" tweeter
- 88dB+/- 3dB sensitivity @1W/1m
- Nominal Power
- 2,5/5/10/20W/8ohm with
- 100V/70V line transformer
- Building-in hole 170mm

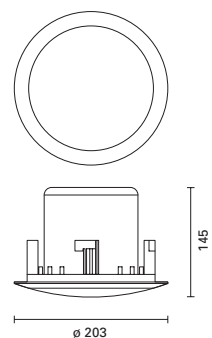



## CSL 630 TIC

**Code 29417**

### IN-CEILING SPEAKER WITH METAL GRILLE

- Metal back cover
- Colour white RAL9016,
- Coaxial loudspeaker with
- 6" woofer and 1/2" tweeter
- Nominal Power 3.8/7.5/15/30W/80hm with 100V/70V line transformer
- 90-20,000Hz frequency response
- 88dB+/- 3dB sensitivity @1W/1m
- Dimensions 230x150mm
- Building-in hole 200mm

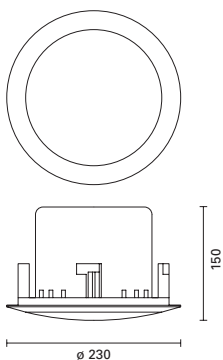

## CSL 840 TIC

**Code 29418**

### IN-CEILING SPEAKER WITH METAL GRILLE

- Metal back cover
- Colour white RAL9016,
- Coaxial loudspeaker with
- 8" woofer and 1/2" tweeter
- Nominal Power 5/10/20/40W/80hm with 100V/70V line transformer
- 90-20,000Hz frequency response
- 88dB+/- 3dB sensitivity @1W/1m
- Dimension 270x185mm
- Building-in hole 240mm

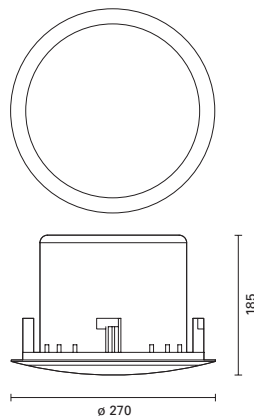

## CSL 606 TWP

**Code 29428**

### ABS WEATHER-PROOF IN-CEILING SPEAKER

- Plastic basket and white RAL 9016 grille
- 5" loudspeaker with coaxial 1" tweeter, water-resistant and resistant to the corrosion due to outdoor mounting
- 100V integrated transformer
- Low impedance socket (8ohm)
- Maximum power 45W (Rated 20W)

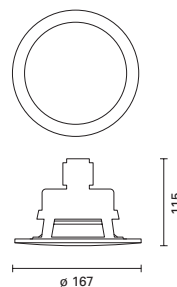



		<b>SAFE 10 PT</b>	<b>WCS 650</b>	<b>WSH 1006</b>	<b>FPS/505T</b>	<b>AQUA 30</b>	<b>IW 105 T</b>
<b>Code</b>		<b>09356</b>	<b>29470</b>	<b>29419</b>	<b>35302</b>	<b>10436</b>	<b>30154</b>
Type		IP56 weatherproof and V0 self-extinguishing, with transformer	ABS ceiling/wall mounting speaker	Wall speaker with painted metal protective grill	ABS surface mounting wall speaker	IP68 watertight	ABS surface mounting ceiling loudspeaker
Colour	RAL	White 9010	White	White	White	Blue NCS 1070B	White
Loudspeaker		-	Dual cone loudspeaker with 6.5" cone	Dual cone loudspeaker with 5.5" cone	Woofer 5" 1/4 con dome tweeter	-	2-way, 4" woofer with 1" dome tweeter
Frequency response	Hz	150÷20.000	80÷18.000	130÷15.000	120÷20.000	80÷20.000	60÷20.000
Sensitivity 1W/1m	dB	85	93	92	90	105	88
Mounting system		Screw fit	Supports included	-	Screw fit	Recessed or on bracket included	-
Rated/Maximum power	W	-	-	-	-	20/30	-
Maximum SPL	dB	15	10	6	10	20	15
Power taps	W RMS	10 / 15	2.5 / 5 / 10	3 / 6	10 / 4 ohm	20/8ohm	1 / 2 / 4 / 7,5 / 15
Transfrmer	V	-	100	100	100	-	100
Accessories		-	-	-	-	-	Surface mounting recess RB100
Dimension (WxHxD)	mm	206x55x104	ø 264x85	210x320x85	184x271x37	ø 137x53	146x220x72
Weight	Kg	0,8	1	1,4	1	2,5	1,3



		<b>MCSL 006 TW</b>	<b>MCSL 006 TWP</b>	<b>CSL 106/T</b>	<b>CSL 520 TIC</b>	<b>CSL 630 TIC</b>	<b>CSL 840 TISC</b>	<b>CSL 606 TWP</b>
<b>Code</b>		<b>29425</b>	<b>29426</b>	<b>29427</b>	<b>29416</b>	<b>29417</b>	<b>29418</b>	<b>29428</b>
Type		ABS In-ceiling speaker with metal grille	ABS In-ceiling speaker with metal grille	In-ceiling speaker with metal grille	ABS In-ceiling speaker with metal grille	ABS In-ceiling speaker with metal grille	ABS In-ceiling speaker with metal grille	ABS weather-proof in-ceiling speaker
Colour	RAL	White 9016	White 9016	White 9016	White 9016	White 9016	White 9016	White 9016
Frequency response	Hz	120:20.000	150:18.000	100:15.000	100:20.000	90:20.000	50:20.000	95:20.000
Sensitivity 1W/1m	dB	87	91	93	88	88	88	90
Maximum SPL	dB	91	95	-	-	-	-	-
Input voltage	V	100	100	100	100 / 70	100 / 70	100 / 70	100
Power taps	W RMS	3 / 6	3 / 6	3 / 6	2.5 / 5 / 10 / 20	3.8 / 7.5 / 15 / 30	5 / 10 / 20 / 40	20
Cut-out diameter	mm	95	125	150	170	200	240	122
Dimension (WxHxD)	mm	ø 103x80	ø 140x130	ø 175x60	ø 203x14	ø 230x150	ø 270x185	ø 167x115
Weight	Kg	0,5	0,9	0,5	1,8	2,3	3,1	0,7



## CESL 10T

**Cod. 29420**

**ALUMINIUM WEATHER-PROOF  
SOUND PROJECTOR**

- White RAL9016
- 5" dual cone loudspeaker
- 10/5/2.5 Watt power
- 100V Transformer
- SPL 1W/1m 91dB
- Dispersion (-6dB) @2kHz 110°

## CESL 20T

**Cod. 29421**

**ALUMINIUM WEATHER-PROOF  
SOUND PROJECTOR**

- White RAL9016
- 6,5" dual cone loudspeaker
- 20/10/5Watt power
- 100V Transformer
- SPL 1W/1m 92dB
- Dispersion (-6dB) @2kHz 110°

## CESL 10T BIDI

**Cod. 29429**

**ALUMINIUM WEATHER-PROOF  
SOUND PROJECTOR**

- White RAL9016
- 2x5" dual cone loudspeaker
- 10/5/2.5 Watt power
- 100V Transformer
- SPL 97dB@100V 5W
- Dispersion (-6dB) @2kHz 110°  
for each direction



## GB 820/T

**Code 29430**

### ABS SPHERICAL SPEAKER

- White RAL9016
- 8" dual cone loudspeaker
- 360° horizontal and 140° vertical dispersion (@2kHz)
- 20 Watt power
- 100V Transformer
- Equipped with 2 mt cable

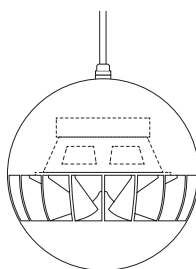

ø 254





## MHS 50T

Code 29431

### ABS WEATHER-PROOF TWO-WAY MUSIC HORN SPEAKER

- Wide frequency-response
- Stainless steel adjustable bracket, ABS light grey body treated to be resistant to sunlight
- 50Watt power with 100V transformer

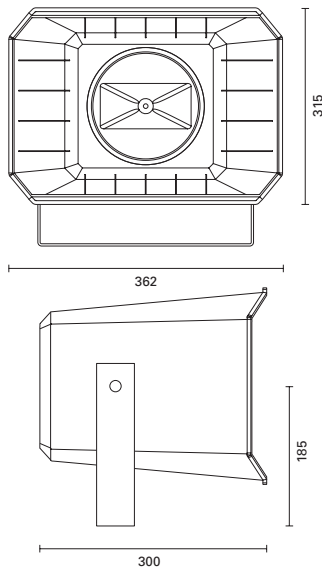

## HS 50T

Code 29422

### ALUMINIUM ABS WEATHER-PROOF CIRCULAR HORN SPEAKER

- 100V line transformer
- Suitable for internal and external environments
- RAL7035
- Stainless steel bracket
- Double insulation

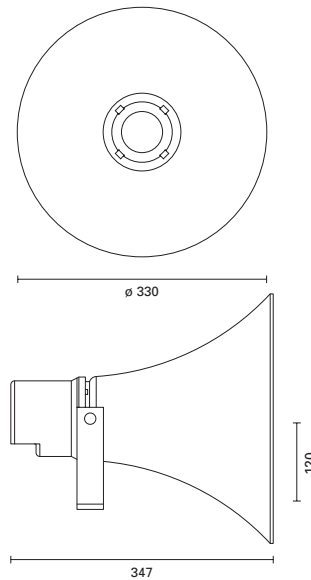



### **PH 10 T**

**Code 11474**

**IP 66 WEATHER-PROOF ABS  
CIRCULAR HORN SPEAKER**

- RAL 7035 light grey colour
- Stainless steel U bracket
- Power 10/5/2,5/1,25 Watt
- 100V / 70V transformer
- SPL 1W/1m 106dB
- UV protection

### **PH 20 T**

**Code 11475**

**IP 66 WEATHER-PROOF ABS  
CIRCULAR HORN SPEAKER**

- RAL 7035 light grey colour
- Stainless steel U bracket
- Power 20/5/2,5 Watt
- 100V / 70V transformer
- SPL 1W/1m 108dB
- UV protection

### **PH 30 T**

**Code 10446**

**IP 66 WEATHER-PROOF ABS  
CIRCULAR HORN SPEAKER**

- RAL 7035 light grey colour
- Stainless steel U bracket
- Power 30/15/7.5/3.75 Watt
- 100V / 70V transformer
- SPL 1W/1m 110dB
- UV protection



	<b>CESL 10T</b>	<b>CESL 20T</b>	<b>CESL 10T BIDI</b>	<b>GB 820/T</b>
<b>Code</b>	<b>29420</b>	<b>29421</b>	<b>29429</b>	<b>29430</b>
Type	IP44 Weather-proof Sound Projector	IP44 Weather-proof Sound Projector	IP44 Bidirectional Weather-proof Sound Projector	ABS spherical speaker
Colour	RAL White 9010	White 9010	White 9010	White
Loudspeaker	5" dual cone loudspeaker	6,5" dual cone loudspeaker	2x5" dual cone loudspeaker	8" dual cone
Frequency response	Hz 130÷15.000	110÷15.000	130÷15.000	130÷15.000
Sensitivity 1W/1m	dB 91	92	91	92
Mounting system	Bracket	Bracket	Bracket	-
Rated/Maximum power	W 10 / 5 / 2,5	20 / 10 / 5	10 / 5 / 2,5	20 / 10 / 5
Input voltage	V 100	100	100	100
Dispersion	° 110	110	110 bidirezionale	360 horizontal 140 vertical
Transformer	V 100	100	100	100
Accessories	-	-	-	2 m cable
Dimensions (WxHxD)	mm ø 138x205	ø170x252	ø 138x205	ø 254
Weight	Kg 2,2	2,8	2,8	2,2



	<b>MHS 50T</b>	<b>HS 50T</b>	<b>PH 10T</b>	<b>PH 20T</b>	<b>PH 30 T</b>
<b>Code</b>	<b>29431</b>	<b>29422</b>	<b>11474</b>	<b>11475</b>	<b>10446</b>
Type	ABS weather-proof two-way music horn speaker	Aluminium ABS weather-proof circular horn speaker	IP 66 weather-proof ABS circular horn speaker	IP 66 weather-proof ABS circular horn speaker	IP 66 weather-proof ABS circular horn speaker
Colour	RAL Light gray 7035	Light gray 7035	Light gray 7035	Light gray 7035	Light gray 7035
Loudspeaker	-	-	-	-	-
Frequency response	Hz 90÷20.000	360÷6.500	400÷8.000	350÷8.000	330÷8.000
Sensitivity 1W/1m	dB 99	109	106	108	110
Rated/Maximum power	W 50	-	-	-	-
Maximum SPL	dB	126	116	121	124
Input voltage	V -	100	-	-	-
Dispersion	° -	-	180 / 70	180 / 60	180 / 60
Rated/Maximum power	W 50 / 25 / 12,5 / 9 / 4,5 RMS / 3,5	-	10 / 5 / 25 / 1,25	20 / 10 / 5 / 2,5	30 / 15 / 7,5 / 3,75
Transformer	V -	100	100 / 70	100 / 70	100 / 70
Accessories	Stainless steel adjustable bracket	Stainless steel bracket	Stainless steel U bracket	Stainless steel U bracket	Stainless steel U bracket
Dimensions (WxHxD)	mm 362x315x300	ø 330x347	ø 138x200	ø 203x254	ø 238x287
Weight	Kg 3,9	2,3	1,3	1,9	2,1





STYLE A50



STYLE P50

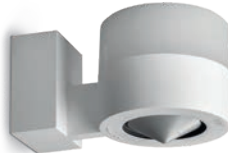

STYLE S50

Combines high quality sound play with innovative design, creating a new concept and a catching look that are able to satisfy several architectural needs.

The sound speaker shall no more be hidden, with the risk of affecting the sound quality. Instead, it will be integrated in the environment, combining form and function, acoustics and integration in the environment.

The nature itself has inspired this loudspeaker: in the nature the sound spreads to all directions, and, hence, we have developed a speaker that could reproduce a natural sound feeling. The sound diffusion in the nature is 360°, whereas in standard speakers its propagation is conic-shaped and, hence, has a narrow angle.

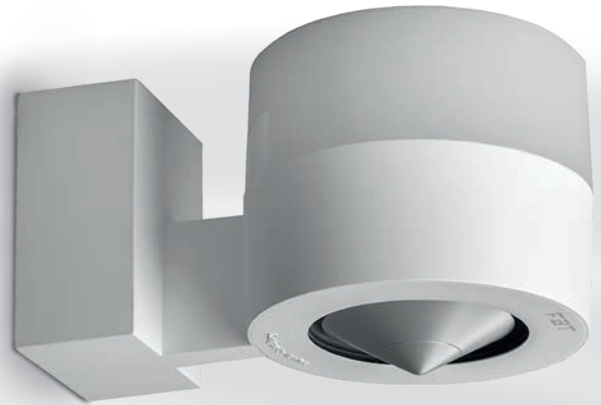

## STYLE A50 / A40T

Code 39625 / 39626

## STYLE P50 / P40T

Code 39627 / 39628

## STYLE S50 / S40T

Code 39629 / 39630

### SPEAKER SYSTEMS

Thanks to the conic-shape of the diaphragm, STYLE sound speakers provide a 360° sound diffusion, reaching even the highest frequencies. The sound diffusion spreads to all directions, keeping the sound natural and accurate even when the volume is very high.

Thanks to this new technology you will immediately forget the geometric diffusion you are used to and you will be able to recreate a holographic and three-dimensional sound effect in any environment.

Moreover, thanks to the material Style speakers are made of and to the aluminium loudspeaker, they are suitable for outdoor mounting and resist to various weather conditions.

- 360° even sound diffusion
- Even sound diffusion over a wide frequency range (105Hz-20kHz) to all directions
- They can be powered using standard amplifiers
- The listening position is not bound by the orientation towards the axis
- Perfect both for high-fidelity systems and for sound diffusion in environments such as train stations, airports, restaurants, shopping centres etc.
- Full end even sound energy pressure everywhere in the environment
- High sound efficiency
- Excellent results with reference to the Larsen effect thanks to the sound energy that is reduced to one fourth towards the microphone
- Low intermodulation
- Low second harmonic distortion
- Classic modern design, perfect for any environment

### TR-20

Switching unit

Code 31011

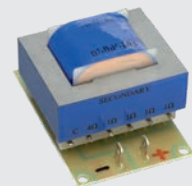



In order to offer suitable solutions for each sound system, **PROJECT** loudspeakers have been developed with characteristics such as to be used in all environments with the same high sound quality.

The PROJECT series is characterized by a very compact two-way system that guarantees high power handling, wide dynamics, faithful music reproduction and a high degree of speech intelligibility. The predisposition for their simple assembly greatly simplifies the installation phase, reducing time and costs. The 1020SA model is an active subwoofer, small in size but providing high power; thanks to the frequency, volume and phase adjustments it is particularly suitable in a configuration with PROJECT series satellites.



### PROJECT 1020 SA

**Code 44147**  
**white ral 9003**

**ABS SPEAKER SYSTEM**

- 10" active studio monitor subwoofer

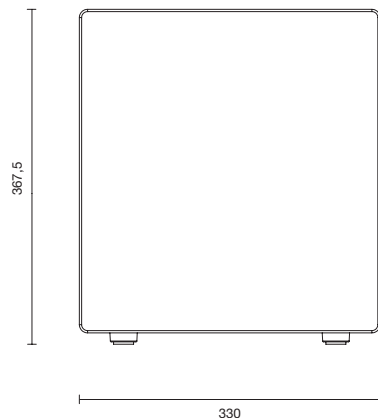

### PROJECT 1020 SA

**Code 44222**  
**black ral 9005**

**ABS SPEAKER SYSTEM**

- 10" active studio monitor subwoofer

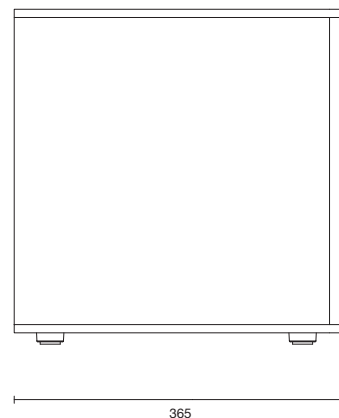



	1020 SA	1020 SA
<b>Code</b>	<b>44147</b>	<b>44222</b>
Features	Class AB design Low cut selectable for output 12 dB / oct X-over Auto-standby	Class AB design Low cut selectable for output 12 dB / oct X-over Auto-standby
Color	RAL White 9003	Black 9005
Type	10" active studio monitor subwoofer	10" active studio monitor subwoofer
Frequency response	Hz 40 - 150	40 - 150
Impedance	Ohm 4	4
Max peak SPL	dB 110	110
Driver	10" subwoofer / pp cone / big-roll edge	10" subwoofer / pp cone / big-roll edge
Cabinet	MDF with vinyl finish	MDF with vinyl finish
Inputs	Stereo XLR / TRS balanced Stereo RCA unbalanced	Stereo XLR / TRS balanced Stereo RCA unbalanced
Outputs	Stereo XLR balanced	Stereo XLR balanced
Power output	W 150 RMS	150 RMS
Input impedance	10 kOhm balanced 20 k unbalanced	10 kOhm balanced 20 k unbalanced
LF crossover point	Hz 80 - 120 adjustable	80 - 120 adjustable
HF punto di crossover	Hz 80 - 150 adjustable	80 - 150 adjustable
Volume	Main volume control	Main volume control
Phase	Normal / Rev switchable	Normal / Rev switchable
AC power input	Hz 115 V / 230 V~ 50/60 switchable	115 V / 230 V~ 50/60 switchable
Dimension ( W x H x D )	In 12,99 x 14,46 x 14,37	12,99 x 14,46 x 14,37
Net weight	lb 35,27	35,27





**Project WHT**  
White RAL 9010



**Project BT**  
Black RAL 9005



## PROJECT 315

**BT Code 29350**  
**WHT Code 32372**

### ABS SPEAKER SYSTEM

- 2 way bass reflex
- 3.5" woofer and 0.5" tweeter
- 100V line transformer (Multi taps)
- Frequency response @-10dB is 100Hz-15kHz
- Dispersion HxV 120°x120°
- High-pass filter recommended 70Hz-24dB/oct
- 8-piece multiple packing
- 15W/30W nominal/maximum power
- Setting 2/4/7.5/15W/8ohm
- Sensitivity 85dB
- Max SPL 100dB

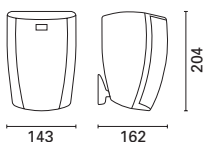

## PROJECT 320

**BT Code 29221**  
**WHT Code 32368**

It has the same characteristics as the 315 version, with the following features:

- 20W/40W nominal/maximum power
- Setting 4/8/15/20W/8ohm
- Sensitivity 87dB
- Max SPL 103dB

## PROJECT 530

**BT Code 29223**  
**WHT Code 32368**

### ABS SPEAKER SYSTEM

- White or black ABS speaker
- 2 way bass reflex
- 5" woofer and 0.75" tweeter
- 100V line transformer(Multi Taps)
- Frequency response @-10dB 85Hz-20kHz
- Dispersion HxV 100°x100°
- High-pass filter recommended 55Hz-24dB/oct
- 30W/60W nominal/maximum power
- Setting 10/15/20/30W/8ohm
- Sensitivity 87.5dB
- Max SPL 106dB

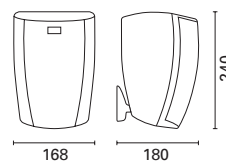

## PROJECT 550

**BT Code 29225**  
**WHT Code 32369**

It has the same characteristics as the 530 version, with the following differing features:

- 50W/100W nominal/maximum power
- Setting 15/25/40/50W/8ohm
- Sensitivity 89dB
- Max SPL 109Db





**Project WHT**  
White RAL 9010



**Project BT**  
Black RAL 9005

## PROJECT 640

**BT Code 29227**  
**WHT Code 32370**

### ABS SPEAKER SYSTEM

- 2 way bass reflex
- 6.5" woofer and 1" tweeter
- 100V line transformer(multi Tapp)
- Frequency response @-10dB  
70Hz-20kHz
- Dispersion HxV 90°x90°
- High-pass filter recommended  
40Hz-24dB/oct
- 4-piece multiple packing
- 40W/80W nominal/maximum  
power
- Setting 10/20/30/40/8ohm
- Sensitivity 89dB
- Max SPL 108dB

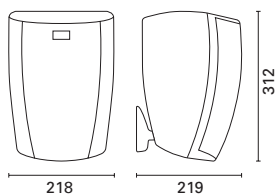

## PROJECT 660

**BT Code 29229**  
**WHT Code 32371**

It has the same characteristics as the 640 version, with the following differing features:

- 60W/120W nominal/maximum  
power
- Setting 15/30/45/60W/8ohm
- Sensitivity 90dB
- Max SPL 111dB



Wall bracket included, manufactured from die-cast aluminium with ball/socket multi angle adjustment capability and steel security cable.



		STYLE A50	STYLE A40T	STYLE P50	STYLE P40T	STYLE S50	STYLE S40T
<b>Code</b>		<b>39625</b>	<b>39626</b>	<b>39627</b>	<b>39628</b>	<b>39629</b>	<b>39630</b>
Type		Ceiling mounted speaker	Ceiling mounted	Suspending mounted	Suspending mounted	Wall mounted	Wall hanging
Principle		One way	One way	One way	One way	One way	One way
Enclosure		high-performance plastic flange (100° - 130° Continuous use) - recyclable - Formstable up to 150° - fireclass UL94 - V-0 self extinguish	high-performance plastic flange (100° - 130° Continuous use) - recyclable - Formstable up to 150° - fireclass UL94 - V-0 self extinguish	high-performance plastic flange (150° Continuous use) - recyclable - Formstable up to 220° - fireclass UL94 - V-0 self extinguish	high-performance plastic flange (150° Continuous use) - recyclable - Formstable up to 220° - fireclass UL94 - V-0 self extinguish	high-performance plastic flange (150° Continuous use) - recyclable - Formstable up to 220° - fireclass UL94 - V-0 self extinguish	high-performance plastic flange (150° Continuous use) - recyclable - Formstable up to 220° - fireclass UL94 - V-0 self extinguish
Colour	RAL	White RAL 9010	White RAL 9010	White RAL 9010	White RAL 9010	White RAL 9010	White RAL 9010
Driver equipment		-	100V t ransformer	-	100V transformer	-	100V transformer
Nominal impedance	ohm	16	-	16	-	16	-
Nominal PWR / Music		50W RMS / 90W	40/20/10/5W RMS	50W RMS / 90W	40/20/10/5W RMS	50W RMS / 90W	40/20/10/5W RMS
Sensitivity (1W@1m 2,83V@1m)		83,4dB @ 16 Ohm	83,4dB	83,4dB @ 16 Ohm	83,4dB	83,4dB @ 16 Ohm	83,4dB
Maximum SPL	dB	100	100	100	100	100	100
Frequency response	Hz	105-20.000 (+/-3dB)	105-20.000 (+/-3dB)	105-20.000 (+/-3dB)	105-20.000 (+/-3dB)	105-20.000 (+/-3dB)	105-20.000 (+/-3dB)
Connectors		Screw-terminal	Screw-terminal	Screw-terminal	Screw-terminal	Press-Terminal	Press-Terminal
Dimensions (WxHxD)	mm	ø 180x25 (in sight) - installation depth 50mm - hole mounting 130mm	ø 180x 25(in sight) - installation depth 50mm - hole mounting 130mm	ø 134x135 + cable standard length 1mt - Baldachin Height 72mm, ø 60mm	ø 134x135 + cable standard length 1mt - Baldachin Height 72mm, ø 60mm	ø 134x130x220	ø 134x130x220
Net weight	lb	0.88	2.88	2.68	3.57	3.28	4.16
Transport weight	lb	1.43	2.91	3.43	4.32	4.05	4.93



		PROJECT 315		PROJECT 320		PROJECT 530		PROJECT 550		PROJECT 640		PROJECT 660	
<b>Code</b>		<b>29350</b>	<b>32372</b>	<b>29221</b>	<b>32367</b>	<b>29223</b>	<b>32368</b>	<b>29225</b>	<b>32369</b>	<b>29227</b>	<b>32370</b>	<b>29229</b>	<b>32371</b>
Colour	RAL	Black 9005	White 9016	Black 9005	White 9016	Black 9005	White 9016	Black 9005	White 9016	Black 9005	White 9016	Black 9005	White 9016
Configuration	vie	2		2		2		2		2		2	
Recommended amplifier	W RMS	30		40		60		100		80		120	
Long term power	W	15		20		30		50		40		60	
Short term power	W	60		80		120		200		160		240	
Nominal impedance	ohm	8		8		8		8		8		8	
Frequency response @-10dB		100Hz-15kHz		100Hz-15kHz		85Hz-20kHz		80Hz-20kHz		70Hz-20kHz		70Hz-20kHz	
Low frequency woofer	mm	88		88		130		130		165		165	
Sensitivity (@1W, 1m)	dB	85		87		87,5		98		89		90	
Max. Spl	dB	100		103		106		109		108		111	
Dispersion	HxV	120x120		120x120		120x120		100x100		90x90		90x90	
Recommended hp filter		70Hz-24dB/oct		70Hz-24dB/oct		55Hz-24dB/oct		50Hz-24dB/oct		40Hz-24dB/oct		40Hz-24dB/oct	
Input connector		Euroblock		Euroblock		Euroblock		Euroblock		Euroblock		Euroblock	
Dimensions (WxHxD)	mm	143x204x162		143x204x162		168x240x180		168x240x180		218x312x219		218x312x219	





## ARCHON 105

## ARCHON 106

### AC-W 568

Directional wall metal bracket  
Code 36987



For ARCHON 105 and  
ARCHON 106

### AC-W 568W

Directional wall metal bracket  
Code 37330



White for ARCHON 105  
and ARCHON 106

### Code 36250

#### PERMANENT INSTALLATION SPEAKER SYSTEM

- Passive Sound Reinforcement  
200W / 8 ohm - 115dB SPL
- 1 x 5" (1.25" VC) custom made LF woofer with  
rubber surround
- 1 x 1" HF dome tweeter
- 4 x M5 threaded rigging points
- Optional line transformer 50W

### Code 36251

#### PERMANENT INSTALLATION SPEAKER SYSTEM

- Passive Sound Reinforcement  
300W / 8 ohm - 119dB SPL
- 1 x 6.5" (1.5" VC) custom made LF woofer with  
rubber surround
- 1 x 1" HF dome tweeter
- 6 x M5 threaded rigging points
- Optional line transformer 100W



## ARCHON 108

**Code 36252**

### PERMANENT INSTALLATION SPEAKER SYSTEM

- 2-way, passive sound reinforcement systems
- Passive Sound Reinforcement  
350W / 8 ohm - 121dB SPL
- 1 x 8" (1.5" VC) custom made LF woofer with rubber surround
- 1 x 1.5" HF high-end dome tweeter
- 8 x M5 threaded rigging points
- 12mm (0.47") baltic birch plywood cabinets
- Custom designed LF woofers, made in Italy
- Custom designed HF dome tweeter, Made in Italy
- Crossover networks equipped with 4 x Euroblock speaker terminals; factory preset for optimal line transformer installation
- Multiple M5 threaded rigging points
- Acoustically transparent steel grille and antistat protection cloth
- New FBT rotatable logo badge following vertical or horizontal installation
- Optional line transformer 100W
- Optional mounting hardware

## ARCHON 208S

**Code 36256**

### PERMANENT INSTALLATION SPEAKER SYSTEM

- Subwoofer passivo in Bass-Reflex
- 600W / 8ohm 132dB SPL
- 2 woofer alta escursione da 200 mm (50 mm VC)
- Cabinet in multistrato di betulla 15 mm
- Due maniglie integrate
- 2 connettori Speakon NL-4



		<b>ARCHON 108</b>	<b>ARCHON 106</b>	<b>ARCHON 105</b>	<b>ARCHON 208S</b>
<b>Code</b>		<b>36252</b>	<b>36251</b>	<b>36250</b>	<b>36256</b>
Configuration	vie	2	2	2	1
Recommended amplifier	W RMS	350	300	200	600
System Long term power	W	175	150	100	300
System Short term power IEC 268-5	W	700	600	400	1200
Input	V	100	100	100	100
Nominal impedance	ohm	8	8	8	8
Frequency response		55Hz - 22KHz @-6dB	60Hz - 22KHz @-6dB	70Hz - 22KHz @-6dB	50Hz - 500Hz @-6dB
Low frequency woofer	mm	8 - 1.5 bobina	6.5 - 1.5 bobina	5 - 1.25 bobina	2 x 8 - 2 coil
AES power	W	150	120	70	150
High frequency driver	mm	1.5 - 1.5 bobina dome	1 - 1 bobina dome	1 - 1 bobina dome	-
AES power	W	150	120	20	-
Sensitivity (@1W/1m)	dB	92,5	91	89	95
Maximum SPL cont/peak (Bi-Amp)	dB	118 / 121	116 / 119	112 / 115	129 / 132
Dispersion HxV	HxV	90°	100°	110°	omni
Crossover frequency	kHz	2	2,5	3	external active
Recommended HP filter		40hz - 24dboct	45hz - 24dboct	60hz - 24dboct	40hz - 24dboct
Recommended external filter		-	-	-	Digital management with presets
Input connectors		4 x Euroblock 0-8-100V (low-high)	4 x Euroblock 0-8-100V (low-high)	4 x Euroblock 0-8-100V (low-high)	2 x Speakon NL4 in & thru
Dimensions (WxHxD)	mm	248x411x248	216x360x216	180x300x180	550x285x480
Weight	kg	6,5	5,5	4	18

Perfect for the reproduction of high-quality speech/vocal application in reverberant environments, it can be used also for sound reinforcement as well as for fixed installations



DLA 804A



DLA 1244A

## VERTUS DLA 804A

**Code 36186**

### DIGITAL CONTROL ACTIVE LINE ARRAY

- Possibility of stacking on a subwoofer from the MITUS range through the optional mounting accessory and of wall-mount installation with the supplied bars
- Standard white finish RAL 9016
- 16 x 50W RMS - 126dB SPL
- 2-way active column line array with digital beam steering technology
- 12 x 100mm (4") full-range custom speakers with 25mm (1") voice coil
- 4 x 25mm (1") dome neodymium tweeter on waveguides
- Frequency response from 100Hz to 20kHz
- 16 x 50W RMS power amplifiers in Class D with switching mode power supply for a total of 800 W RMS
- the 2 way system design allows a high-quality full-range reproduction of the musical signal

## VERTUS DLA 1244A

**Code 36187**

### DIGITAL CONTROL ACTIVE LINE ARRAY

- Possibility of stacking on a subwoofer from the MITUS range through the optional mounting accessory and of wall-mount installation with the supplied bars
- Standard white finish RAL 9016
- 8 x 50W RMS - 123dB SPL
- Active column line array with digital beam steering technology
- 8 x 100mm (4") full-range custom speakers with 25mm (1") voice coil
- Frequency response from 120Hz to 10kHz
- 8 x 50W RMS power amplifiers in Class D with switching mode power supply for a total power of 400 W RMS



CS3130/TW

CS3150/TW

CS3180/TW

## CS3130/TW

## CS3150/TW

## CS3180/TW

### W-8

#### Wall fastening bracket

Code 38661



### Code 37922

#### COLUMN SPEAKER WITH ALUMINIUM BODY

- Power 30 Watt RMS with
- 100V transformer and 7.5/15/30W power selection
- Frequency response 180Hz-18kHz
- Sensitivity 91dB
- Maximum SPL 106dB
- 4x2" speakers + 1x1" tweeter
- Horizontal dispersion (-6dB) 1kHz/4kHz 180°/120°

### Code 37923

#### COLUMN SPEAKER WITH ALUMINIUM BODY

- Power 50 Watt RMS with
- 100V transformer and 12,5/25/50W power selection
- Frequency response 180Hz-18kHz
- Sensitivity 91dB
- Maximum SPL 108dB
- 10x2" speakers + 1x1" tweeter
- Horizontal dispersion (-6dB) 1kHz/4kHz 180°/120°

### Code 37924

#### COLUMN SPEAKER WITH ALUMINIUM BODY

- Power 80 Watt RMS with
- 100V transformer and 20/40/80W power selection
- Frequency response 180Hz-18kHz
- Sensitivity 91dB
- Maximum SPL 110dB
- 14x2" speakers + 1x1" tweeter
- Horizontal dispersion (-6dB) 1kHz/4kHz 180°/120°





	VERTUS DLA 1244A		VERTUS DLA 804A
<b>Code</b>		<b>36187</b>	<b>36186</b>
Configuration	way	16	8
Built-in amplifier LF/HF	W RMS	16x40	8x40
Built-in amplifier peak LF/HF	W	16x100	8x100
Frequency response	6dB	100Hz - 20KHz @-6dB	120Hz - 20KHz @-6dB
Low frequency woofer	mm	12 x 4 - 1 coil	8 x 4 - 1 coil
High frequency driver	mm	4 x 1 - 1 coil - neodymium	-
Maximum SPL cont/peak	dB	123 / 126 dB	120 / 123 dB
Dispersion HxV	HxV	100° x Digital Controlled	100° x Digital Controlled
Steering Angle		+30 / -30V	+30 / -30V
Beamwidth Angle		10 / 40V	10 / 40V
Input impedance	Kohm	22	22
Crossover frequency	kHz	3	3
Ac power requirements	VA	650	400
Input connector		Euroblock with loop and SUB OUT	Euroblock with loop and SUB OUT
Power cord	m	5	5
Net dimensions (WxHxD)	mm	130x1685x131	130x965x131
Net weight	kg	22	13



	CS3130/TW	CS3150/TW	CS3180/TW
<b>Code</b>	<b>37922</b>	<b>37923</b>	<b>37924</b>
Material	Aluminium (RAL 9010)	Aluminium (RAL 9010)	Aluminium (RAL 9010)
Grille	Powder Coated ALU Mesh (RAL 9010)	Powder Coated ALU Mesh (RAL 9010)	Powder Coated ALU Mesh (RAL 9010)
Speakers	4x2" LO+1x1" HI	10x2" LO+1x1" HI	14x2" LO + 1x1" HI
Colour	RAL White 9010	White 9010	White 9010
Frequency response	kHz 180~18	180~18	180~18
Sensitivity	dB 91	91d	91
Power Taps	W 7,5 / 15 / 30 / 8Ω	12,5 / 25 / 50 / 20Ω	20 / 40 / 80 / 28Ω
Line input	V 100	100	100
Net dimensions (WxHxD)	mm 405x74,5x69	802x74,5x69	1018x74,5x69
Net weight	kg 1,7	3,5	4,4

# OUTDOOR SPEAKERS



High performance and efficiency for a wide range of professional **indoor or outdoor** applications.



## SHADOW 105T

**Code 36192**

### ALL WEATHER SPEAKERS

- Multipurpose 5" Full Range 120W/8ohm - 112dB SPL
- 2 way configuration with an high power 5" cone and 1" dome for high frequencies
- 100V line transformer with selectable 50W/25W power tapping
- Die-cast aluminum wall bracket with ball/socket for multi angle adjustment capability, with a security cable
- 4 wires cable to select the desired power tapping
- Water-stop grill with 3 layers of protection
- IP55 weather resistant
- Standard grey finish RAL 7011

## SHADOW 108CT

**Code 361943**

### ALL WEATHER SPEAKERS

- Multipurpose 8" Coax 450W/8ohm - 124dB SPL
- 8" coaxial woofer with 2" coil and 1" HF driver with 1.4" coil on conical 90° horn
- 100V line transformer with selectable 100W/50W power tapping
- Sturdy molded polyethylene curved enclosure
- Steel U bracket and other included hardware accessories
- 4 wires cable to select the desired power tapping
- Water-stop grill with 3 layers of protection
- IP55 weather resistant
- Standard grey finish RAL 7011

## SHADOW 112CT

**Code 36194**

### ALL WEATHER SPEAKERS

- Multipurpose High Performance 12" Coax 600W/8ohm - 128dB SPL
- 12" coaxial woofer with 2.5" coil and 1" HF driver with 1.7" coil on conical 90° horn
- 100V line transformer with selectable 200W/100W power tapping
- Sturdy molded polyethylene curved enclosure
- 4 wires cable to select the desired power tapping
- Water-stop grill with 3 layers of protection
- IP55 weather resistant
- Standard grey finish RAL 7011





## **GS 20/T**

**Code 29432**

### **GARDEN SOUND SPEAKERS**

---

- Guaranteed to resist to difficult weather conditions
- It can be placed near pools, on terraces or in gardens
- This versatile speaker can be mounted on the surface or underground
- Speaker's base has been designed to guarantee a firm and safe positioning
- Offers extraordinary coverage thanks to its design, enabling a 360° sound dispersion
- 80Hz-15,000Hz frequency response
- 85dB+/-3dB sensitivity
- 100V Transformer
- 4" Woofer
- ABS, green coloured
- Diameter 215x245mm
- Net weight 2.1Kg



		SHADOW 105CT	SHADOW 108CT	SHADOW 112CT
<b>Code</b>		<b>36196</b>	<b>36193</b>	<b>36194</b>
Configuration	vie	2	2	2
Recommended amplifier	W RMS	120	450	600
Long Term power	W	60	225	300
Short term power (IEC 268-5)	W	240	900	1200
Input	V	100 / 50	100 / 100	100 / 200
Nominal impedance	ohm	8	8	8
Frequency response		90Hz - 20KHz @-6dB	80Hz - 20KHz @-6dB	70Hz - 20KHz @-6dB
Low Frequency woofer	mm	5 - 2.5 coil	8 - 2 coil	12 - 2.5 coil
AES power	W	50	200	250
Hihg frequency driver	mm	1 - 1.7 coil	1 - 1.4 coil	1 - 1.7 coil
AES power	W	10	25	50
Sensitivity (@1W/1m)	dB	98	95	98
Maximum SPL cont/peak	dB	109 / 102	120 / 124	124 / 128
Dispersion	HxV	100°	90° conical	90° conical
Crossover Frequency	kHz	3	1.8	1.6
Recommended HP filter		70hz - 24dboct	60hz - 24dboct	50hz - 24dboct
Input connector		7 wire cable	4 wire cable	4 wire cable
Net Dimension (WxHxD)	mm	168x222x200	285x285x250	430x430x400
Net Weight	kg	3,5	7	15



		GS 20/T
<b>Code</b>		<b>29432</b>
Colour	RAL	green
System	vie	1 dua cone
IP - Rating		IP55
Power taps	W	20/10
Sensitivity	dB	95+/-3
Transformer	V	100
Woofer		4"
Net Dimension (WxHxD)	mm	ø 215x245
Net Weight	kg	2,1

# General information on the various methods of installation

## FBT: EXCELLENCE WITH A VAST SELECTION

FBT offers a vast and comprehensive range of speakers to meet all sound requirements and applications. Specifically designed to enable simple and safe installation, with a modern and eye-catching design, these products are the ideal choice to solve all ambient sound distribution requirements.

All product lines, from recessed ceiling speakers in paint-finished metal or in plastic with dual cone or coaxial speakers, speakers constructed using fire-resistant materials, IP 55-56-68 weatherproof elements, speakers designed for clean rooms or special production departments, to the industrial or entertainment sound models, have been designed according to the latest electro-acoustical parameters.

The result is absolute excellence; perfect music reproduction and optimal voice clarity and speech fidelity. Special attention has been paid to the simplification and reduction in time required for installation and network connections of the power cables, thanks to a special accessory kit supplied as standard.

## WALL APPLICATIONS

If the architectural features of the room are not compatible with a ceiling configuration or if a "wall" application is preferred, it is essential to observe a few basic rules to obtain the best possible sound distribution. In order to maintain the listening point inside the direct signal area, both surface mounted and external speakers, with power from 6 to 20 Watt, should be installed at a height of between 2 and 2.5 m. The maximum distance between adjacent speakers must be no more than 5/6 metres along the length of the room, which should be no wider than 4/5 metres. For wider rooms, e.g. about 8-10 metres, it is recommended to install speakers in an alternated pattern along both the opposing walls in such a way as to provide adequate coverage and maintain sound pressure at the most constant possible level in the area in question (see figures 1 and 2).

A **quick and approximate calculation** can be made of distance  $d$ , which separates the centres of two speakers, when the angle of emission  $A$  and height of the ceiling  $H$  is known:  $d=2*(H-1)*B$

where  $H$  is the height of the ceiling expressed in metres, constant 1 is the height of the listening surface of a seated person and  $B$  is the tangent of  $A/2$ . From the above data, it is evident that for the same ceiling height  $H$ , speakers with wider dispersion angles offer a larger sound diffusion area and therefore a smaller number of speakers are effectively needed.

## The basic principles of effective surface mount ceiling loudspeaker installation

The first priority of a high quality sound reproduction system is that of providing listeners with sound information at an acoustic level that is higher than any possible background noise. The system must simultaneously assure a very wide frequency band and the maximum intelligibility. It should also guarantee a flat frequency response and uniform sound pressure to give optimum listening pleasure and clarity. To meet these requirements, the hypothetical ideal solution would be to place each sound source at an equal distance from all possible listening points.

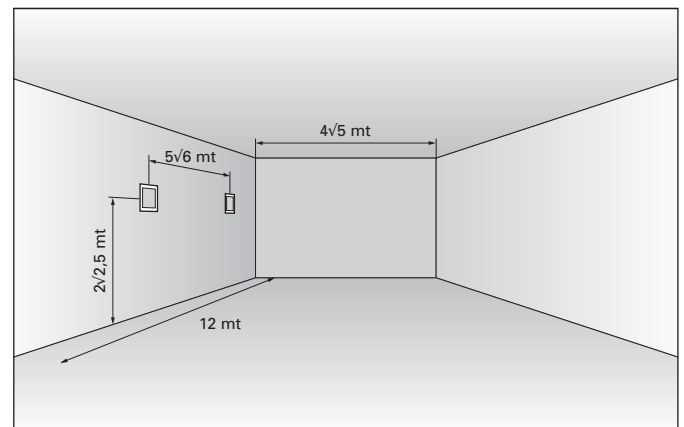

FIGURE 1

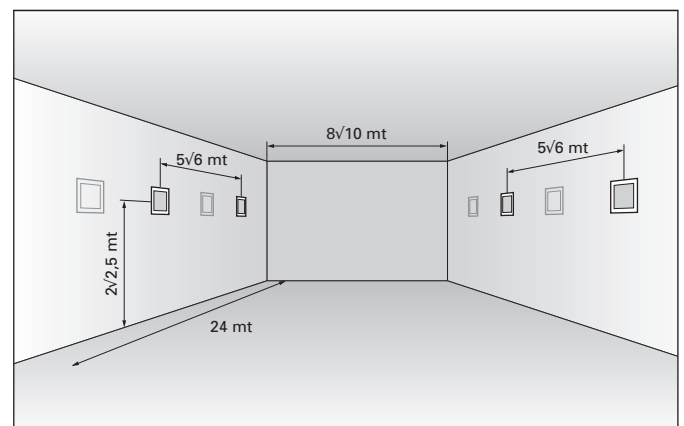

FIGURE 2

## CEILING APPLICATION

In environments offering suitable height, this ideal reference standard can be approximated by using speakers with very wide response and dispersion angles that remain unchanged at different frequencies, arranged in a ceiling or shower type configuration.

This gives the following benefits:

1. Maximum sound distribution uniformity
2. Maximum speech intelligibility
3. Constant quality of music reproduction
4. Reduced presence of reverberation and stationary waves in the environment
5. Sound source remains at a constant distance from the listening position
6. Ample sound energy also at the lowest level

Once the required type of loudspeaker has been chosen, and the characteristic parameters considered (particularly the relationship between the dispersion angle and the room surface area), the number of units needed to obtain constant and uniform sound diffusion can be easily calculated. The number of speakers is calculated by dividing the floor area in square metres by the area of coverage of each loudspeaker on the listening plane. Figure 3 clearly illustrates the above concept.

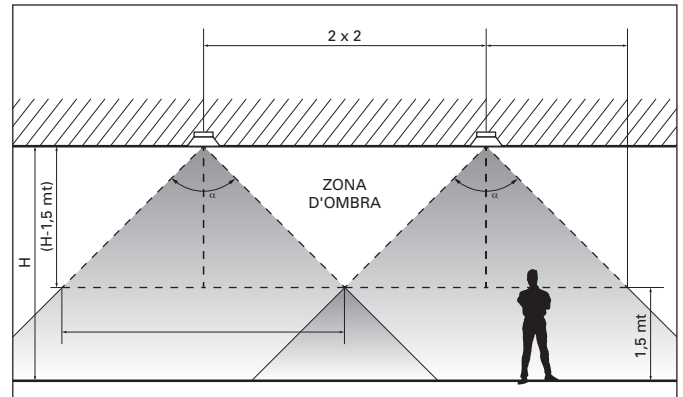

FIGURE 3

Angle of loudspeaker emission	Coefficient B	d with H=3m	d with H=3,5m	d with H=4m	d with H=4,5m
80	0,84	3,36	4,2	5,04	5,88
90	1,00	4	5	6	7
100	1,19	4,76	5,95	7,14	8,33
110	1,43	5,72	7,15	8,58	10,01
120	1,73	6,92	8,65	10,38	12,11
130	2,14	8,56	10,7	12,84	14,98

Figure 4 shows the surface area covered by the sound signal with relative dark zones, and figure 5 with a different grid and greater number of speakers (50%) guarantees maximum uniformity.

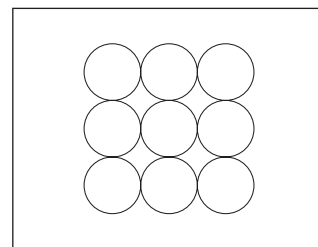

FIGURE 4

Layout of speakers for 80% coverage

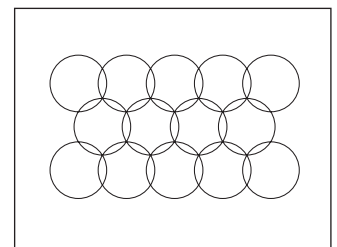

FIGURE 5

Layout of speakers for 100% coverage

For sound distribution in corridors, tunnels, passenger platforms in railway or underground railway stations, horn speakers are used, suited for vocal reproduction, and higher quality speakers called "sound projectors". In all cases these speakers must be installed at a maximum distance of 15 metres from one another, mounted all in the same direction and in observance of the phase of each loudspeaker. Alternatively bi-directional versions of these speakers can be considered, positioned at max. 30 metres from one another and again in observance of the connection phase. (see figure 6)

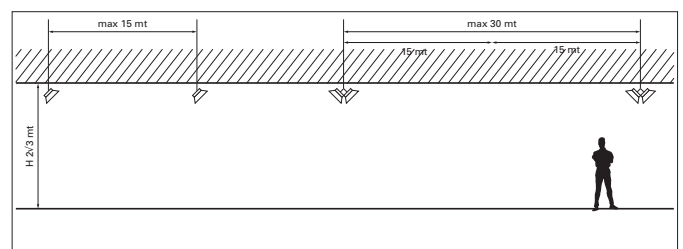

FIGURE 6

# General information on the various methods of installation

## DEGREES OF PROTECTION

The characteristics of a product in terms of its resistance to the penetration of solid objects and liquids is indicated by the letters IP (International Protection) followed by two numbers. The first number identifies the protection against the ingress of solid objects, while the second indicates liquid penetration resistance, in accordance with EN standards 60529-CEI 70-1.

IP degree of protection

- The first number identifies the level of protection against the ingress of solid objects. Number from 0 to 6.
- The second number identifies the level of protection against penetration of liquids. Number from 0 to 8.

First IP number:

- 0 Not protected
- 1 Protected against the ingress of solid objects larger than 50 mm
- 2 Protected against the ingress of solid objects larger than 12 mm
- 3 Protected against the ingress of solid objects larger than 2.5 mm
- 4 Protected against the ingress of solid objects larger than 1 mm
- 5 Protected against dust penetration
- 6 Totally dust-proof

Second IP number:

- 0 Not protected
- 1 Protected against vertically dripping water
- 2 Protected against water dripping at an angle (up to 15° from the vertical)
- 3 Protected against rain
- 4 Protected against water spray
- 5 Protected against water jets
- 6 Protected against waves
- 7 Protected against the effects of temporary immersion
- 8 Protected against the effects of permanent immersion

Constant impedance lines are used above all in the case of a low number of speakers, placed at a minimum distance from the amplifier (<20m).

The constant voltage connection system offers a host of advantages making it ideal for sound systems of all sizes, above all in the case of long distances. This connection system requires each loudspeaker to be equipped with its own line transformer, which adapts the impedance of the loudspeaker (usually very low) to the much higher level of the line itself. In proportion to power transmitted, the current circulating on a line at 100V is considerably lower than that circulating on wires of a constant impedance system, and consequently drops along the line are less frequent; therefore the cable section can be smaller.

The function of the device named **"AMPLIFIER"** is to raise the signal of a sound source, such as a microphone, CD player, cassette recorder or an AM/FM tuner to a sufficient level to pilot the transducer **"LOUDSPEAKER"**.

The amplifier has several inputs, to which the various sound sources are connected.

The sound sources have to be mixed (mixer) and acoustically modified with tone control and equalisers to optimise listening in relation to the environment's characteristics. A terminal board is also fitted on output indicating impedance and voltage to which the loudspeaker line is connected.

A few basic rules must always be observed:

1. **When the load is on "constant impedance", this must be connected to the relative socket.**

For example a load of 4 ohm must be connected to socket marked 4 ohm, and so on. The power that the load can withstand must always be greater than the amplifier's rated power.

**For example in the case of a load of 100 Watt, the amplifier must have a power equal to or less than 100 Watt.**

2. **When the load is at "constant voltage", this must be connected to the sockets indicating output at constant voltage -50-70 or 100 Volt; the power that the load can withstand must always be less than or equal to the amplifier rated power. For example a load of 100 Watt, the amplifier must have a power equal to or greater than 100 Watt.**

**To calculate the value of the amplifier power, simply add together the power of each loudspeaker, in the case of a "constant voltage" system.**

**However, on a constant impedance system, the load must have an equivalent impedance (series/parallel) equal to or greater than the minimum value indicated on the amplifier output.**

The loudspeaker power supply lines, with no connected attenuator, must be with 2 sheathed wires; cables with 3 sheathed wires are required in the case of lines using attenuators which can be disabled if an emergency is activated. Adequate wire sections are required: 1.5 mm<sup>2</sup> for lines up to 500 Watt power

2.5 mm<sup>2</sup> for lines with power over 500Watt. The following general standards must also be observed:

- Never use a single cable (lead) for loudspeaker connections: this would cause disturbance producing a loud "HUM"
- Never use shielded cables for the loudspeaker connections: this would cause serious damage to the power units.



Model	Code	page	Model	Code	page
<b>A</b>			<b>D</b>		
AC 50	38678	79	D8P-1	37936	57
AC 54-D	41356	79	DMM 8008	38885	61
AC 5801	41382	79	DPU 1125 C	37724	18
AC-W568	36987	100	DPU 1250 C	37725	18
AC-W568W	37330	100	DPU 1500 C	37726	18
AFM 2000	41549	20	<b>F</b>		
AL 8000	17074	50	FBT AC CS 1CH	27511	41
AM 5030	11583	69	FBT AC CS 1CU	27510	41
AQUA 30	10436	82	FBT AC CS 1DU	27512	41
ARCHON 105	36250	100	FBT AC D7P-10	37648	41
ARCHON 106	36251	100	FBT AC D7P-20	37649	41
ARCHON 108	36252	101	FBT AC D7PDH-1	37650	41
ARCHON 208S	36256	101	FBT AC EXM-1	37646	42
AVL 606	14142	53	FBT AC EXS-1	37647	42
AW 25	39710	65	FBT AC MX-8	37645	57
AW 25-DIN	39711	65	FBTAC CM 501	27497	55
AW 25 R-DIN	39712	65	FBTAC CX 504	27498	55
<b>B</b>			FBTAC GM 5206L	27515	46
BF-T 5043 L	18322	49	FBTAC GM 5212L	27514	46
BK 560 CRT	09309	78	FBTAC GM 5218L	27513	46
<b>C</b>			FBTAC Mh 750	38376	54
CESL 10T	29420	87	FBTAC Mh 920	38884	55
CESL 10T BIDI	29429	87	FBTAC PT 850B	38901	55
CESL 20T	29421	87	FBTAC ST 5050	27499	48
CM 601	27516	46	FBTAC ST 850	27500	48
CS 3130/TW	37922	104	FBTAC US 8001 D	38640	54
CS 3150/TW	37923	104	FBTAC US 902 D	38375	55
CS 3180/TW	37924	104	FMD 2001	37485	21
CS 4120/EN	40953	32	FMD 2012	37486	21
CS 4130/EN	40954	32	FMG 2000	37488	21
CS 4140/EN	40955	32	FMH 2000	37487	21
CSL 106/T	29427	84	FPS/505T	35302	81
CSL 520 TIC	29416	84	<b>G - H - K</b>		
CSL 606 TWP	29428	85	GB 820/T	29430	88
CSL 630 TIC	29417	85	GS 20/T	29432	108
CSL 840 TIC	29418	85	HM-26	13543	53
CSP 406 T/EN	37727	26	HS 50T	29422	89
CSP 412 T/EN	37728	26	KDT 500 BK	32883	45
CV 2010	35541	51	KMS 400 BK	32882	45

Model	Code	page
<b>I - L</b>		
IW-105T	30154	83
LM-10	13544	53
<b>M</b>		
M 12X4	18147	58
MBT 1101	37739	51
MBT 1106	37492	51
MBT 1112	37493	51
MBT 1112E	37494	51
MB-T 6400 S	28840	49
MB-T 8001	19543	50
MB-T 8004	11828	50
MB-T 8008	12122	50
MC-F 5042	10044	45
MCSL 006 TW	29425	84
MCSL 006 TWP	29426	84
MD-F 5045 SI	15294	45
MDS 1060	37495	72
MD-S 1100	10040	44
MDS 1120	37496	72
MDS 1240	37497	72
MD-S 1300	10042	44
MDS 6120	37643	73
MDS 6240	37644	73
MHO 420 T/EN	37735	26
MHS 50T	29431	89
MMZ 8004 S	19812	59
MPA 5120	37490	68
MPA 5240	37489	19
MPA 5480	37491	19
MPU 2120	31080	66
MPU 4060	31079	66
MPU 4120	31059	66
MPU 4240	31078	66
MSA 100 BK	39321	45
MS02 CD3/DG	27868	76
MS02 CD3/T	27867	76
MSH 15HF/EN	40952	30
MSP 420 TW/EN	37734	28
MSP 420 TWB/EN	40957	28
MXA 1060	37638	70
MXA 1120	37639	70
MXA 3120	37640	71
MXA 3240	37641	71
MZU 2008	12944	60

Model	Code	page
<b>P</b>		
P5201-D	38679	79
P5202-D	38681	79
P5203-D	42338	79
P5204-D	41355	79
P5408-D	42332	79
P5410-D	42333	79
P5416-D	41354	79
P5420-D	42330	79
P5424-D	42331	79
P5430-D	41381	79
P5440-D	40875	79
P5712	40930	79
P5716	41353	79
P5720	42329	79
P5724	42297	79
P5728-L	42649	80
P5736-L	42650	80
P5742-L	42651	80
P5828-L	42652	80
P5836-L	42653	80
P5842-L	42654	80
P5730	41380	79
P5740	40874	79
P5808	40121	78
P5812-D	40929	78
P5816-D	41352	78
P5820-D	42328	78
P5824-D	42296	78
P5830-D	38674	78
P5840-D	40873	78
P8011-D	38680	79
P8012-D	40876	79
P8013-D	41383	79
P8014-D	40878	79
P8032	42335	79
P8035	40877	79
PH 10 T	11474	90
PH 20 T	11475	90
PH 30 T	10446	90
PROJECT 1020 SA	44147	94
PROJECT 1020 SA	44222	94
PROJECT 315 BT	29350	96
PROJECT 315 WHT	32372	96
PROJECT 320 BT	29221	96

Model	Code	page
PROJECT 320 WHT	32367	96
PROJECT 530 BT	29223	96
PROJECT 530 WHT	32368	96
PROJECT 550 BT	29225	96
PROJECT 550 WHT	32369	96
PROJECT 640 BT	29227	97
PROJECT 640 WHT	32370	97
PROJECT 660 BT	29229	97
PROJECT 660 WHT	32371	97
<b>R</b>		
RB-100	18159	83
RWS 412 T/EN	37731	25
<b>S</b>		
SAFE 10 PT	09356	80
SHADOW 105T	36192	107
SHADOW 108CT	36193	107
SHADOW 112CT	36194	107
SHADOW 105T/EN	40646	38
SHADOW 108CT/EN	41808	38
SHADOW 112CT/EN	41809	38
SHADOW 112HCT/EN	41810	37
SHADOW 142L/EN	41811	37
SOP 412 T/EN	37733	29
SOP 426 T/EN	37732	29
SOP 540 T/EN	40956	29
STH 02-022	13360	50
STH 05-022	13103	50
STH 09-022	13104	50
STYLE A50	39625	93
STYLE A40T	39626	93
STYLE P50	39627	93
STYLE P40T	39628	93
STYLE S50	39629	93
STYLE S40T	39630	93
SU 30	11586	45
SWF 142	36350	37
<b>T - U</b>		
TSC6000-EN	40951	20
TR-20	31011	93
USB 3000	37642	71
<b>V</b>		
VAC 2006	37712	16
VAR 2006	37713	17
VAIE 5502	41491	12
VAIE 4101	44605	14

Model	Code	page
VAIE 4102	44606	14
VAIE 4251	44607	14
VAIE 4252	44608	14
VAIE 6502	40644	10
VAIE 6504	40948	10
VAIE 6506	40949	10
VAIE 7502	41812	8
VAIE 7504	41813	8
VAIE 7506	41814	8
VAIE 7M04	42589	8
VAIE 7M06	42610	8
VERTUS CLA 403T B	41807	34
VERTUS CLA 403T W	41824	34
VERTUS CLA 604	36145	32
VERTUS CLA 803T B	41806	34
VERTUS CLA 803T W	41823	34
VERTUS DLA 1244A	36187	103
VERTUS DLA 804A	36186	103
VT-F 3 B	41795	34
VT-F 3 W	41820	34
VT-J 3 B	41794	34
VT-J 3 W	41819	34
VT-W 3 B	41797	34
VT-W 3 W	41821	34
VT-HW 3 B	41798	34
VT-HW 3 W	41822	34
<b>W</b>		
W-8	38661	104
WCS 650	29470	80
WM 505/... (175 Mhz)	40445+40450	53
WM 505/... (214 Mhz)	18472+40449	53
WM 505/... (204 Mhz)	18476+40448	53
WM 505/... (203.25 Mhz)	40447+40452	53
WM 505/... (203.30 Mhz)	31250	53
WM 505/... (216 Mhz)	40446+40451	53
WM 705 A/L (181 Mhz)	14827	53
WM 705 A/L (203 Mhz)	14828	53
WM 705 A/L (207 Mhz)	14830	53
WMS 406 T/EN	37730	25
WSH 1006	29419	81
WSP 406 T/EN	37729	24
WSP 406 TWB/EN	40958	24
WP 8008	38929	61

FBT Elettronica SpA  
has the right to amend products  
and specifications without notice.

ALPS™, B&C and Neutrik™ are the trademarks  
of their respective owners.

Graphics  
**Studio Conti**

Photography  
**Giuseppe Saluzzi**

Printing  
**Tecnostampa - Loreto**

Date of printing: February 2022

FBT.A.C.22/23.0.UK